

EMI_A14	N10	DDR_A14
EMI_A13	T9	DDR_A13
EMI_A12	U11	DDR_A12
EMI_A11	T10	DDR_A11
EMI_A10	U13	DDR_A10
EMI_A09	P10	DDR_A9
EMI_A08	U9	DDR_A8
EMI_A07	N11	DDR_A7
EMI_A06	R9	DDR_A6
EMI_A05	R11	DDR_A5
EMI_A04	U10	DDR_A4
EMI_A03	T11	DDR_A3
EMI_A02	U14	DDR_A2
EMI_A01	U12	DDR_A1
EMI_A00	U15	DDR_A0
EMI_BA2	N12	DDR_BA2
EMI_BA1	T12	DDR_BA1
EMI_BA0	T16	DDR_BA0
EMI_D15	F17	DDR_DR15
EMI_D14	F13	DDR_DR14
EMI_D13	H17	DDR_DR13
EMI_D12	H13	DDR_DR12
EMI_D11	J14	DDR_DR11
EMI_D10	G14	DDR_DR10
EMI_D09	H15	DDR_DR9
EMI_D08	G16	DDR_DR8
EMI_D07	M17	DDR_DR7
EMI_D06	L14	DDR_DR6
EMI_D05	P17	DDR_DR5
EMI_D04	P13	DDR_DR4
EMI_D03	N14	DDR_DR3
EMI_D02	P15	DDR_DR2
EMI_D01	M13	DDR_DR1
EMI_D00	N16	DDR_DR0
EMI_CLK	L17	DDR_CLKR_P
EMI_CLK	L16	DDR_CLKR_N
EMI_CKE	T13	DDR_CKE
EMI_CE0	P12	DDR_CS
EMI_CEI	P9	
EMI_WE	T15	DDR_WE
EMI_RAS	R16	DDR_RAS
EMI_CAS	U16	DDR_CAS
EMI_DQS1	J17	DDR_RDQS1_P
EMI_DQS1	J16	DDR_RDQS1_N
EMI_DQS0	K17	DDR_RDQS0_P
EMI_DQS0	K16	DDR_RDQS0_N
EMI_DQM1	F15	DDR_ROOM1
EMI_DQM0	M15	DDR_ROOM0
EMI_DDR_OPEN	K14	DDR_DQGATE0
EMI_DDR_OPEN_FB	L15	DDR_DQGATE1
EMI_VREF1	K13	VREF_DDR2
EMI_VREF0	R14	
EMI_ODT1	T17	
EMI_ODT0	R17	DDR_ODT

ClassName: DDR2
i DDR2

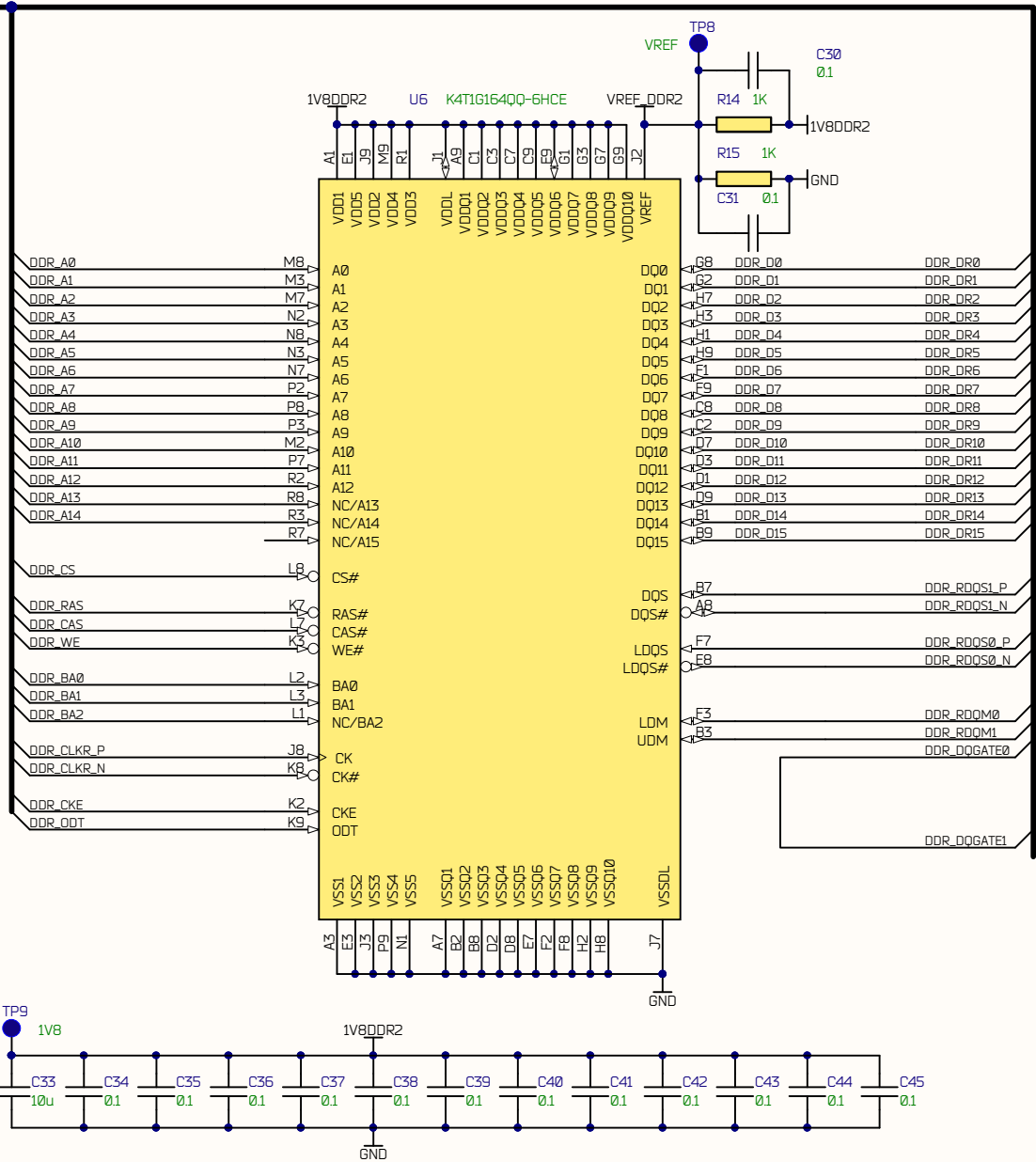

U40 IMX287

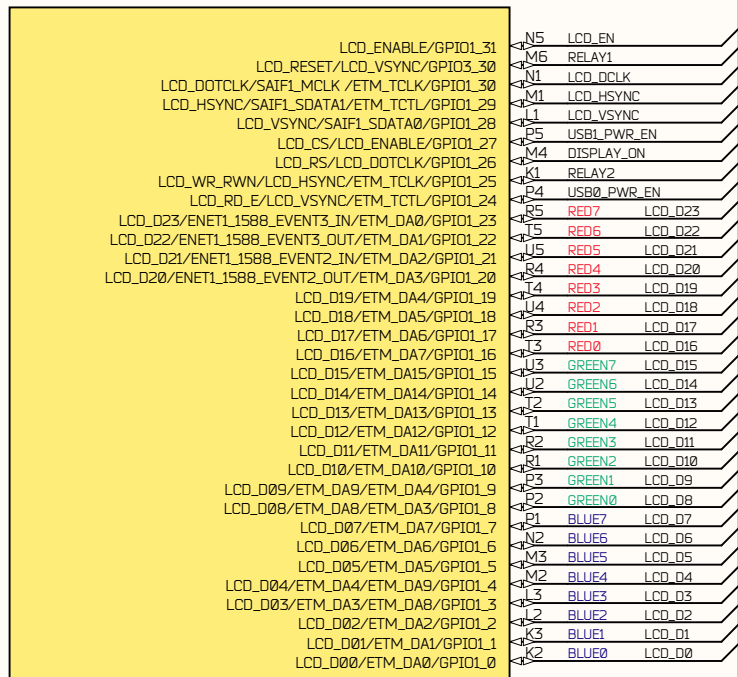

X15 VIDEO OUT

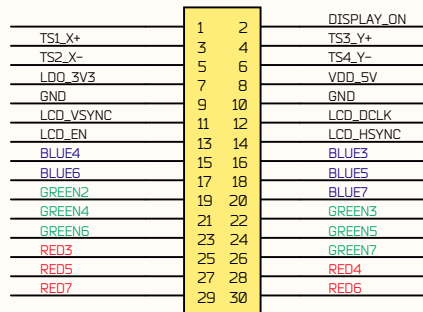

X17 EXPANSION

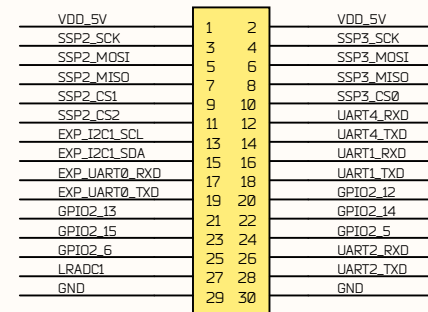

X18 JTAG

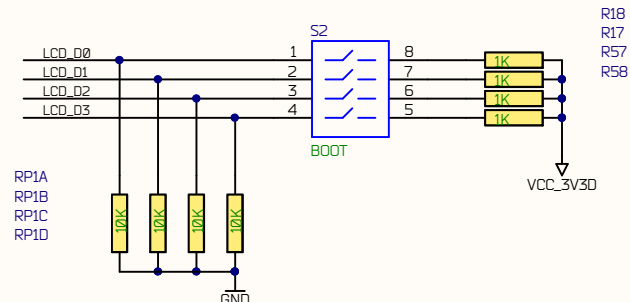
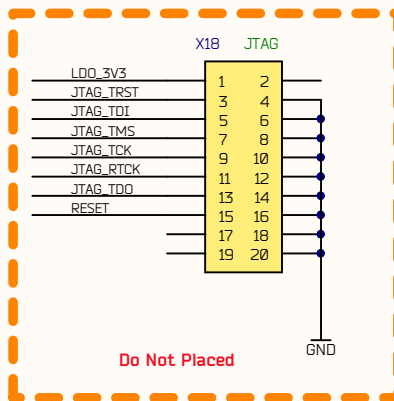

Voltage select 3V3

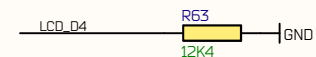

ETM Disable

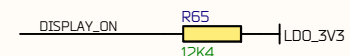
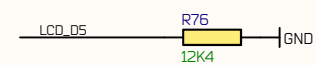

OTP/DIP SWITCH

U4C IMX287

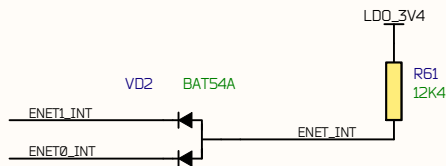
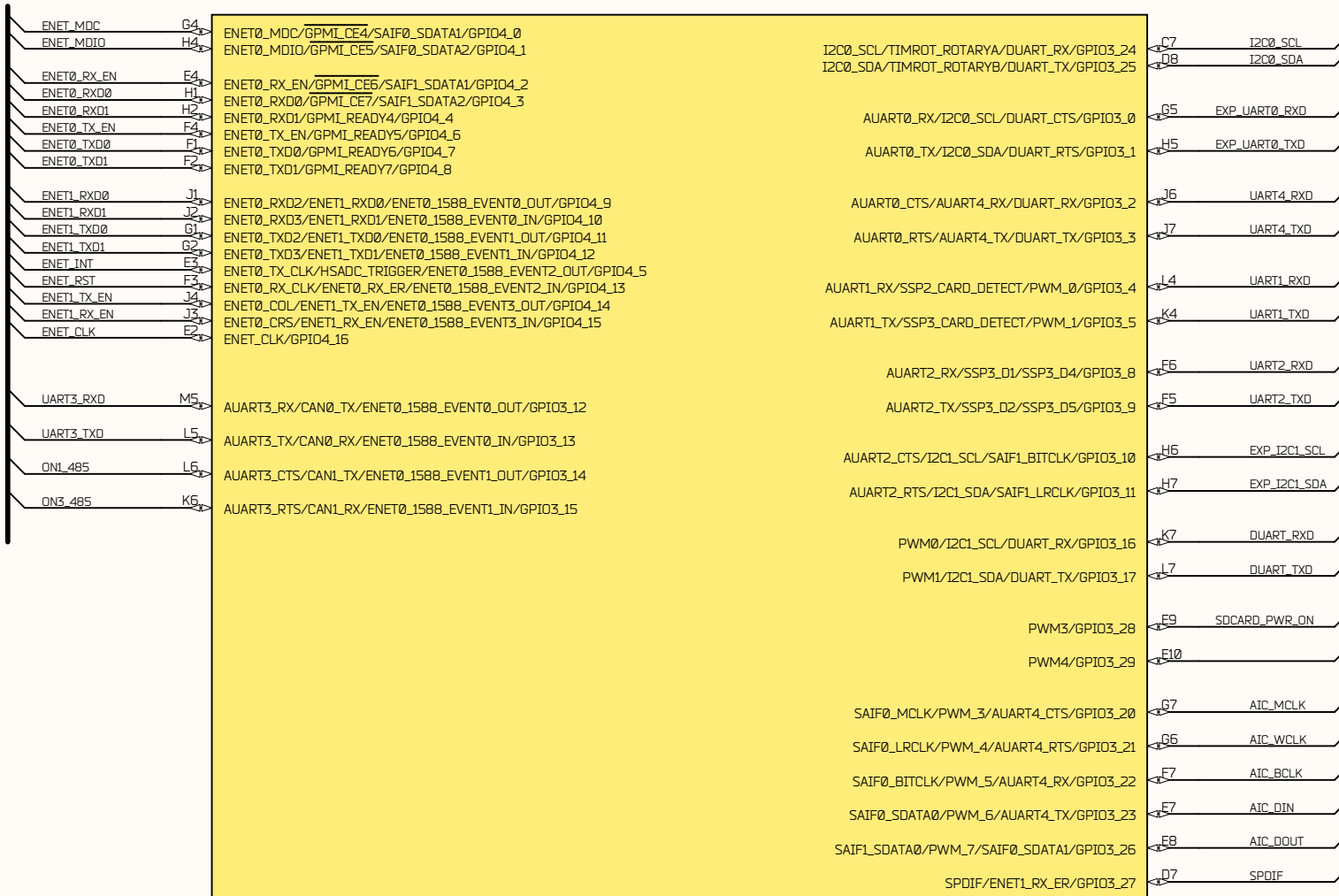

Title		EV-iMX287	
Size: A4	Number:	Revision:	
Date: 02.07.2012	Time: 15:49:07	Sheet	of
www.evodbg.com			



D

C

B

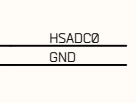
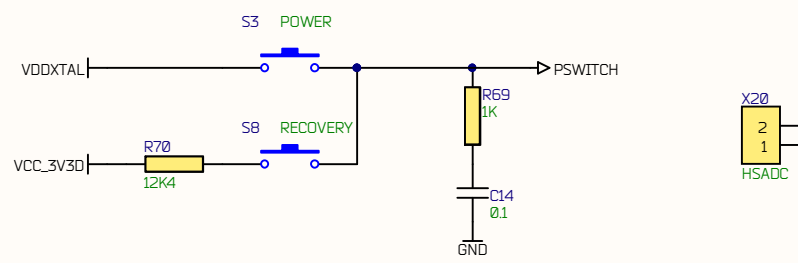
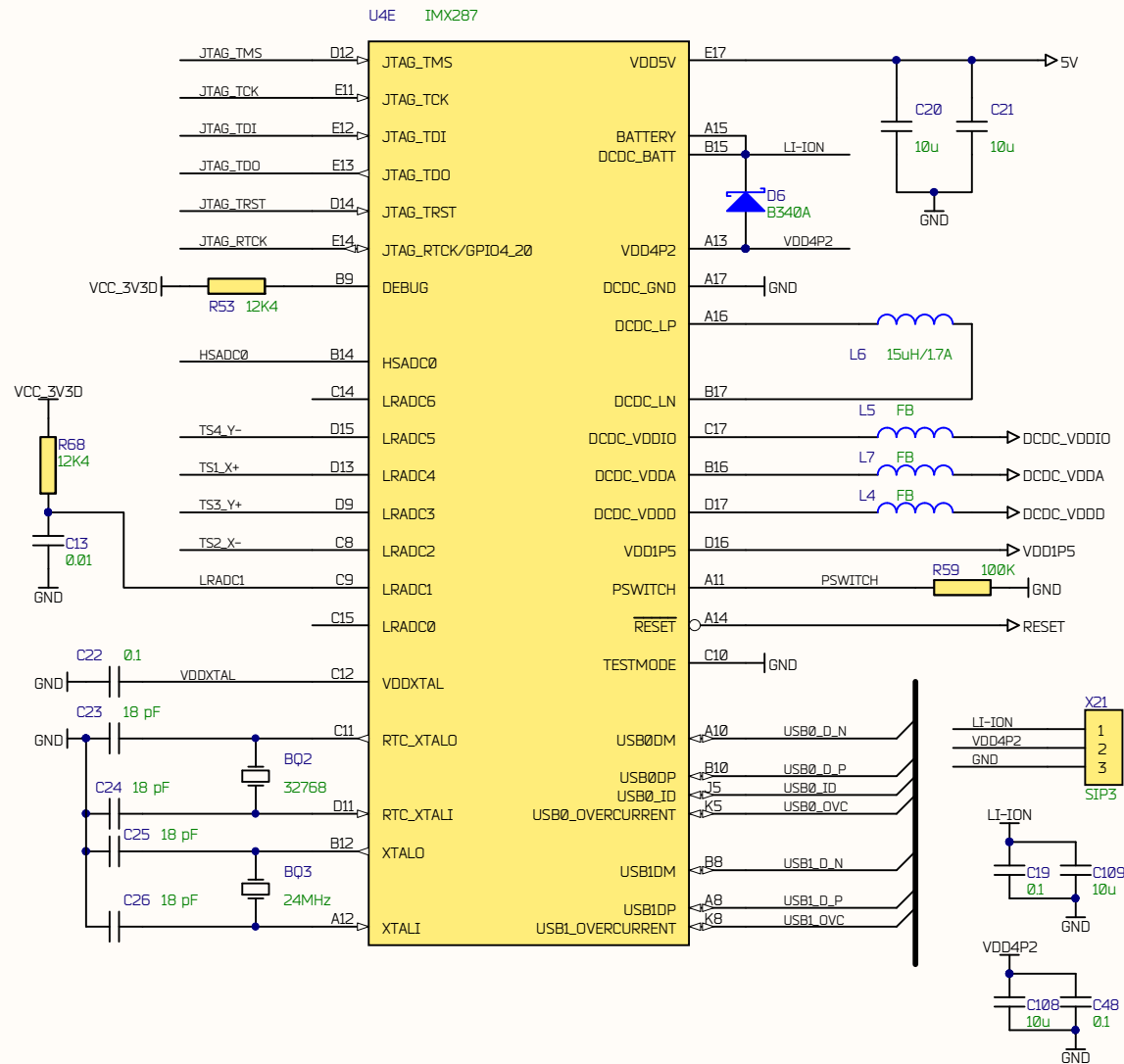
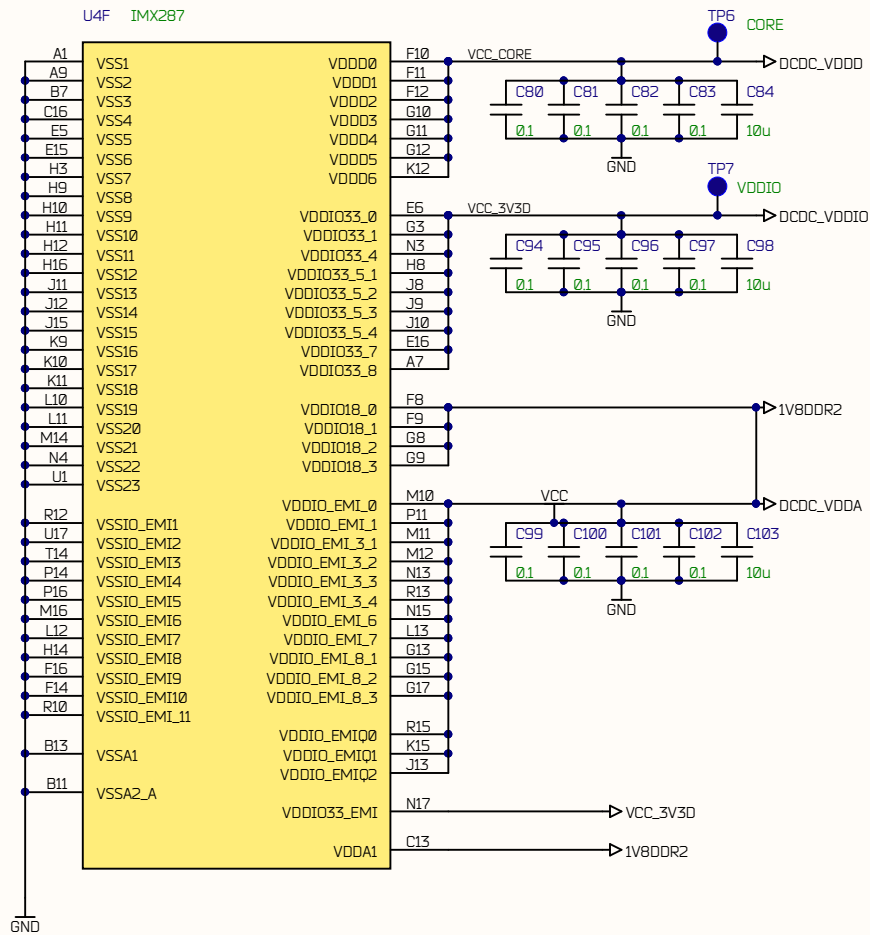

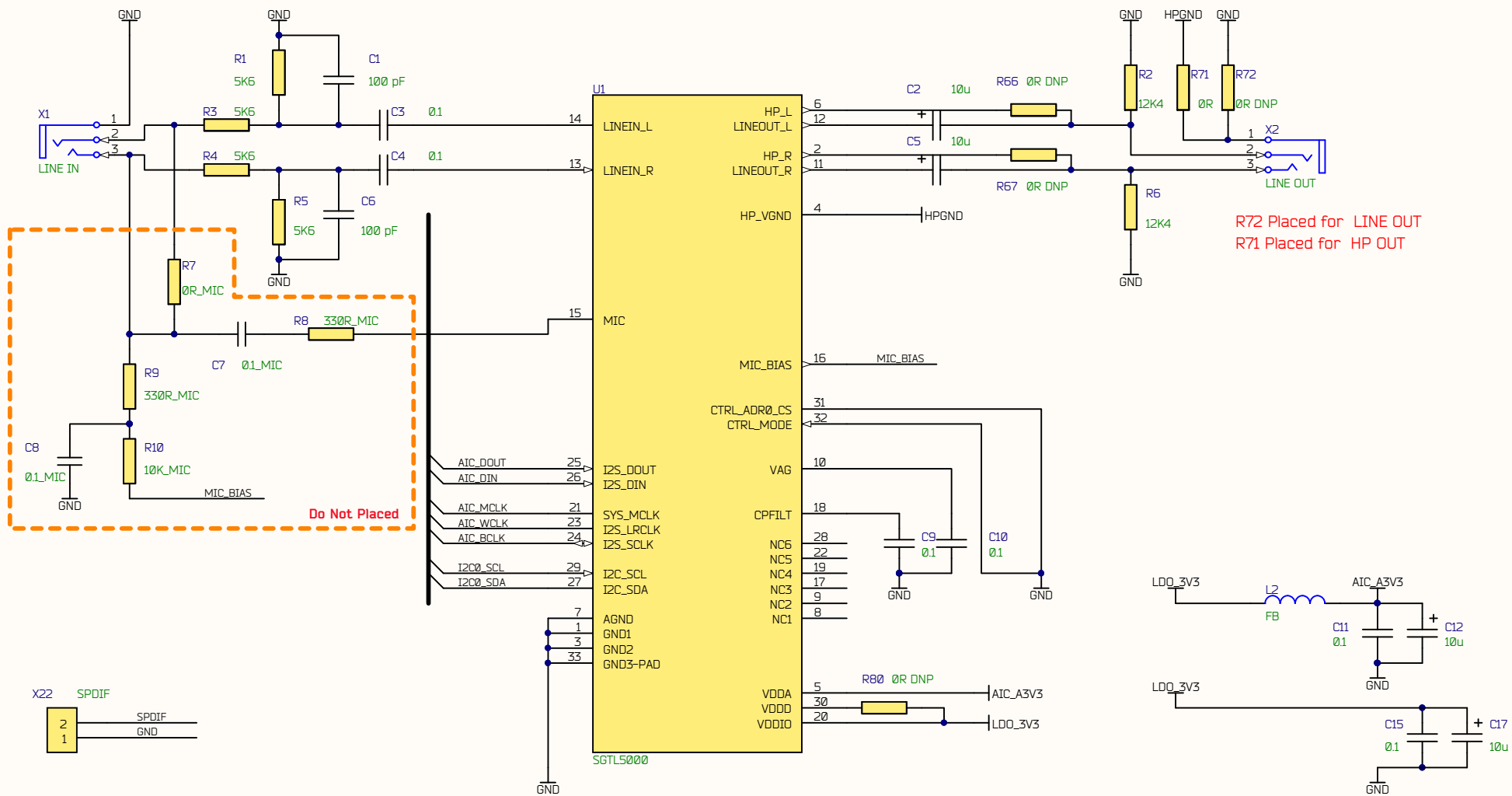

Title **EV-iMX287**

Size: **A4**

Number:

Revision:

Date: **02.07.2012**

Time: **15:47:47**

Sheet of

www.evodbg.com



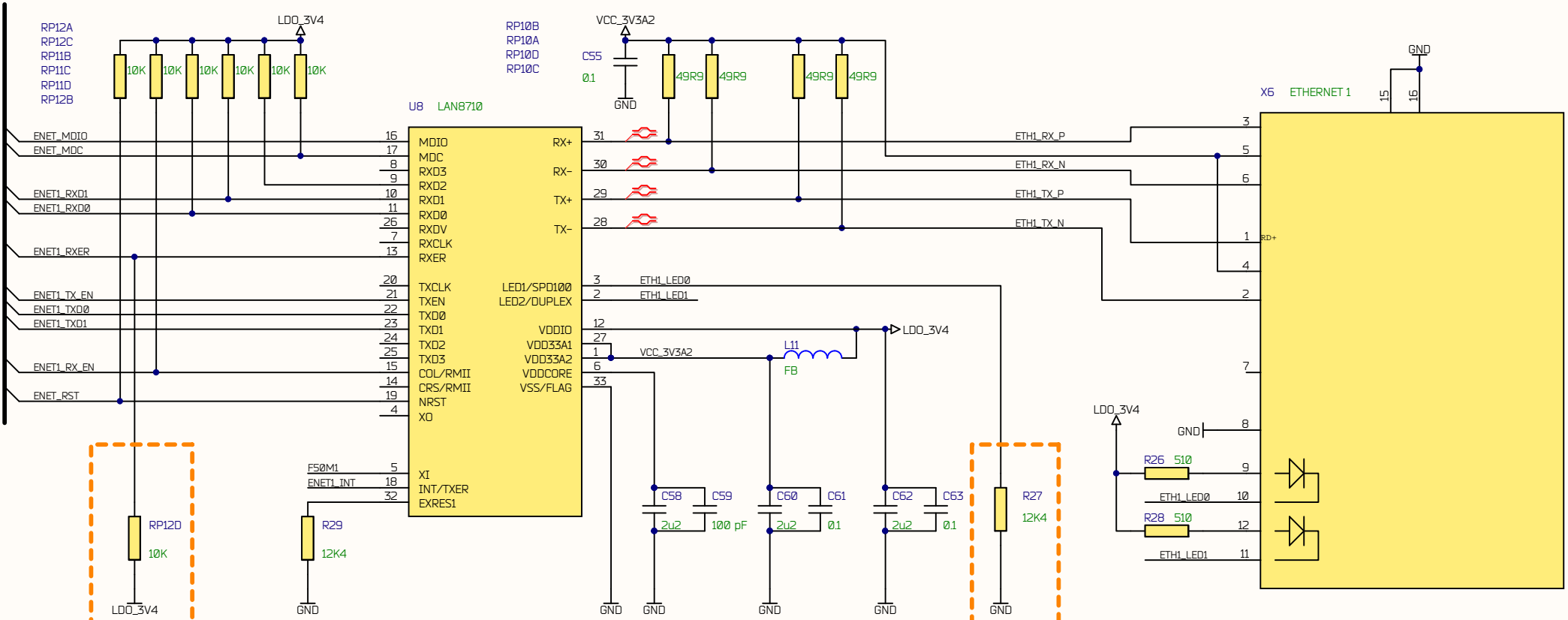

PHY Address 001

Enabled internal LDO 1V2

Title		EV-iMX287	
Size: A4	Number:	Revision:	
Date: 02.07.2012	Time: 15:50:12	Sheet of	
www.evodbg.com			



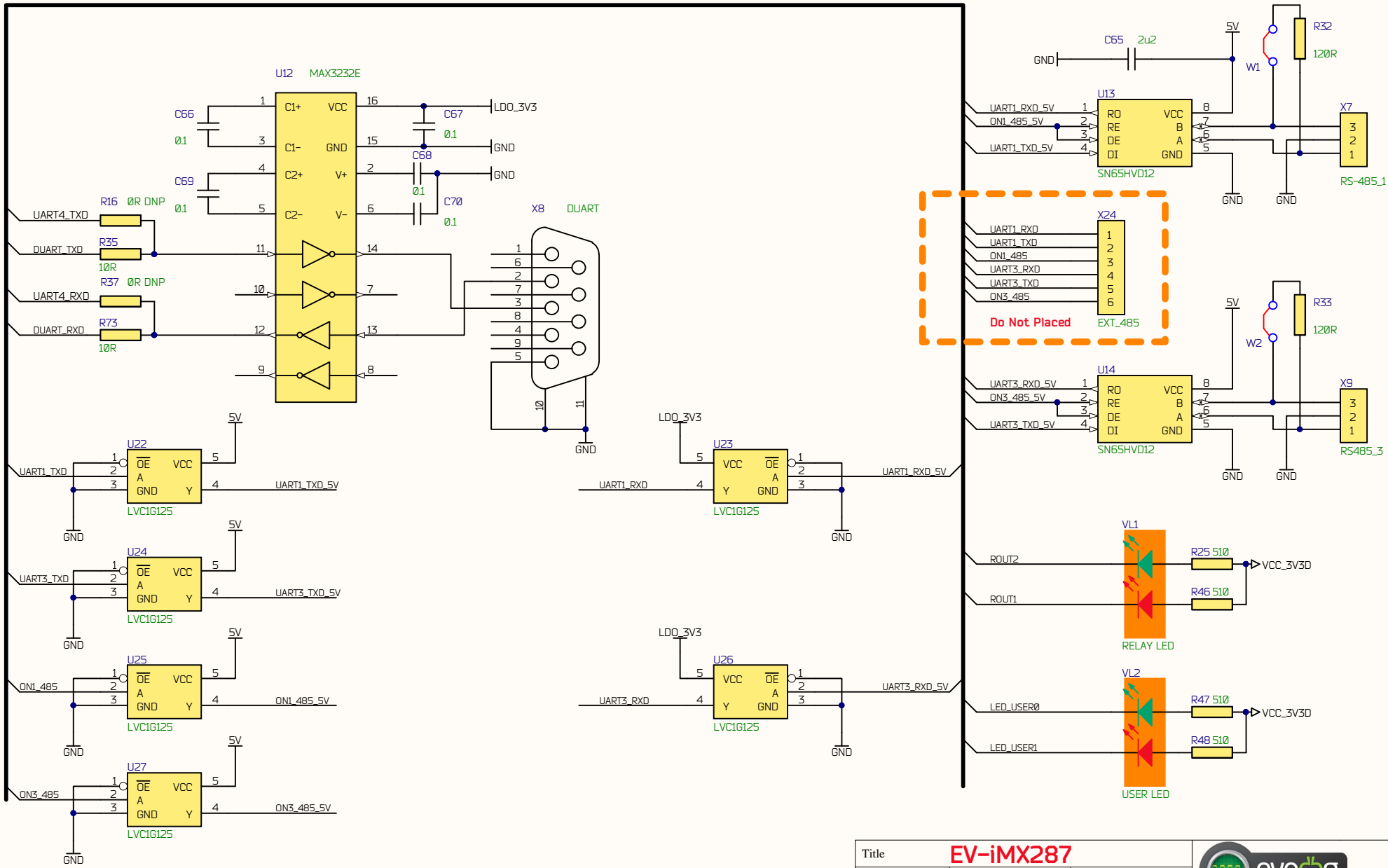

D

C

B

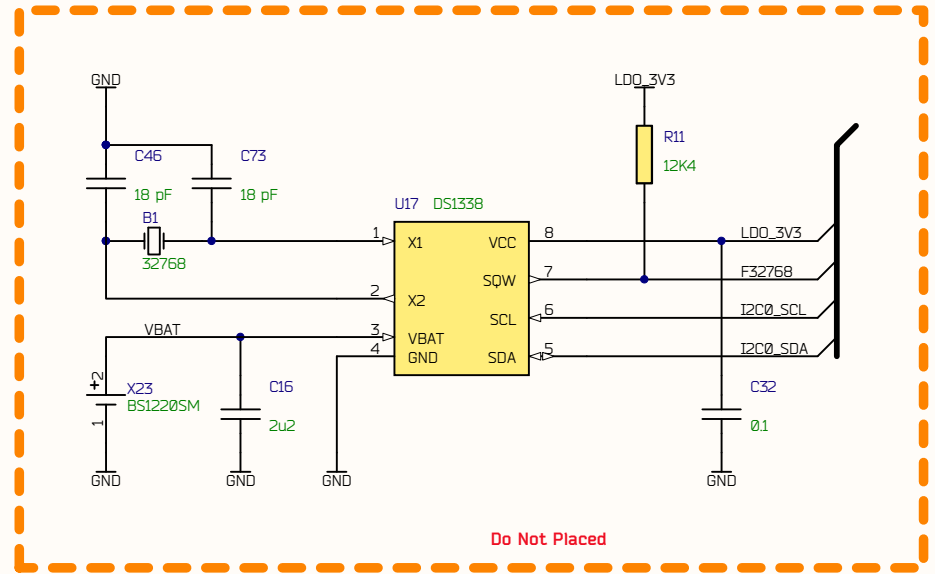
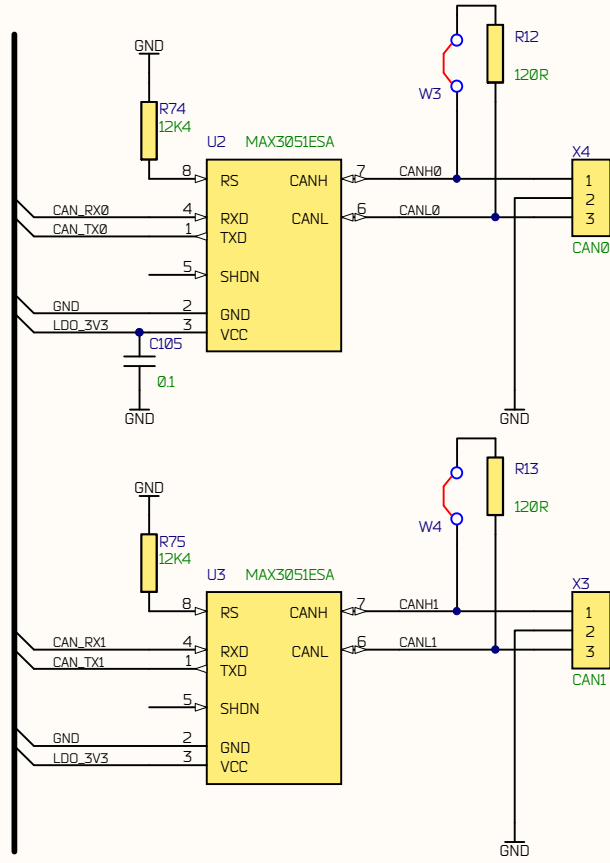

Do Not Placed

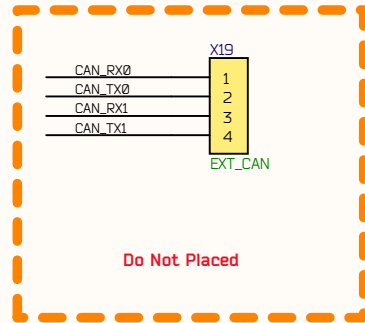

Do Not Placed

Title		EV-iMX287	
Size: A4	Number:	Revision:	
Date: 02.07.2012	Time: 15:53:38	Sheet	of
www.evodbg.com			



D

C

B

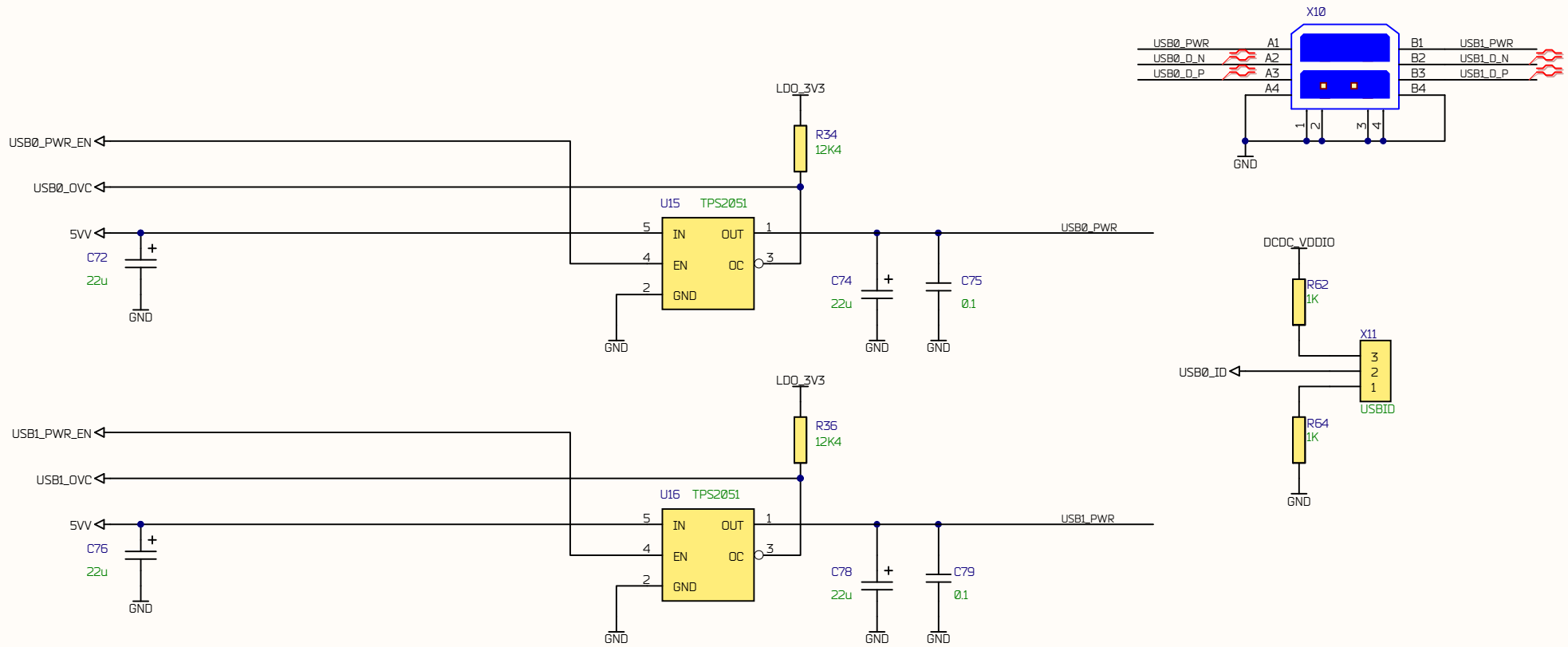

Title		EV-iMX287	
Size: A4	Number:	Revision:	
Date: 02.07.2012	Time: 15:54:05	Sheet of	
www.evodbg.com			



D

C

B

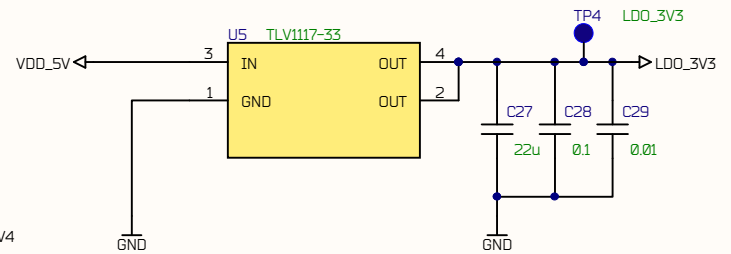
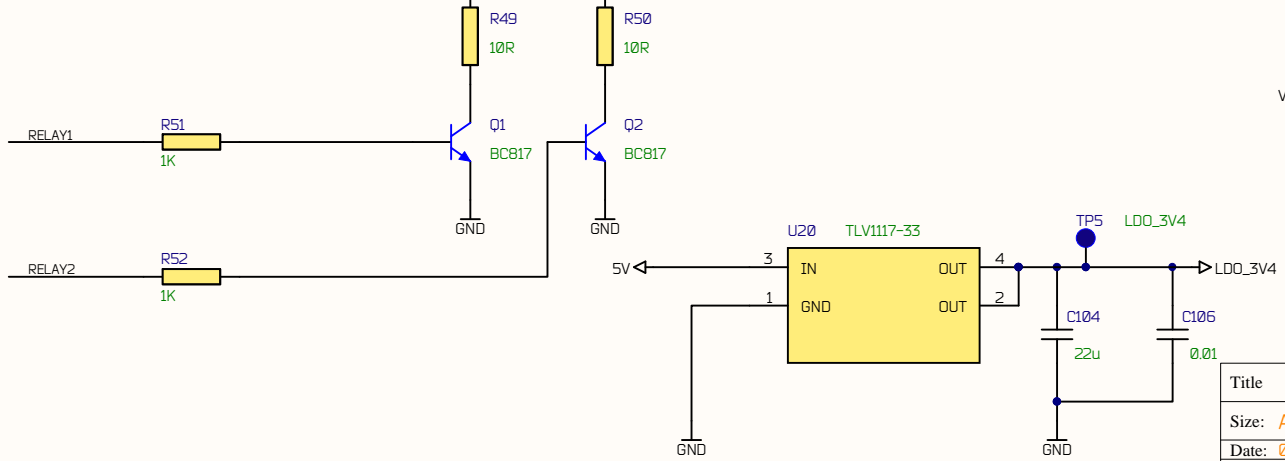
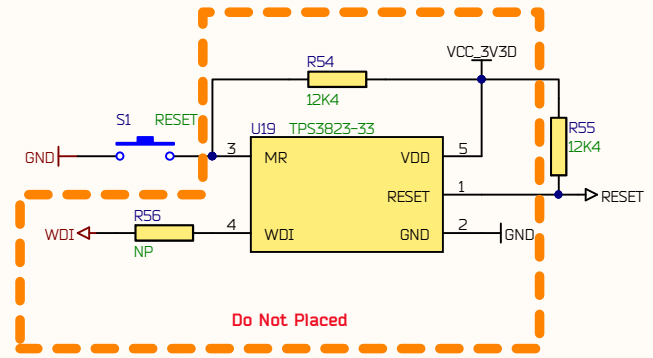
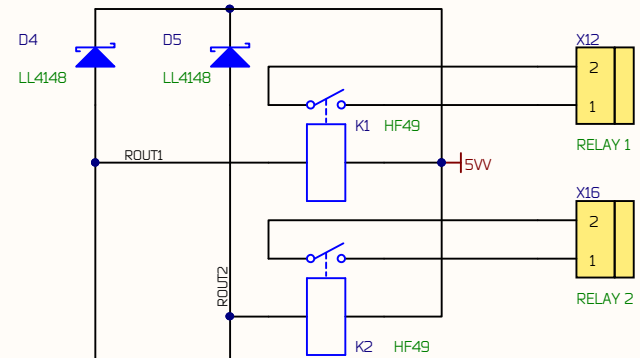
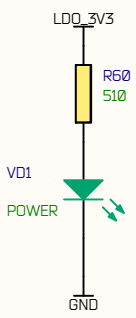
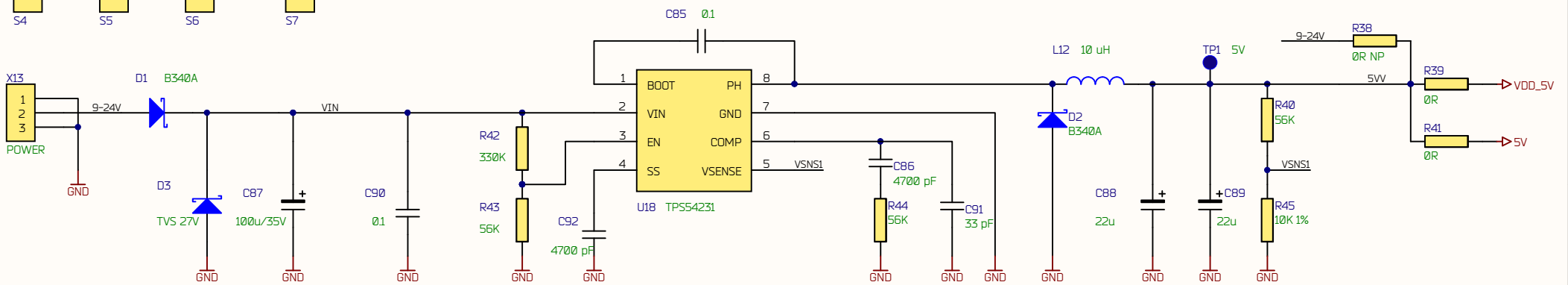
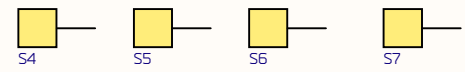

Title EV-iMX287		
Size: A4	Number:	Revision:
Date: 02.07.2012	Time: 15:54:56	Sheet of
www.evodbg.com		

