

## Content:

1. DDR2 Memory
2. Nand Flash, I2C, SPI Memory, SD card
3. Ethernet MAC
4. Ethernet Phy 0
5. Ethernet Phy 1
6. RS-485, Debug RS-232, User leds, Relay leds
7. CAN0, CAN1, External RTC
8. USB, USB power switch
9. LCD Connector, Expansion Connector, Boot Dip-Switch
10. Audio Codec, IN/OUT Connectors
11. Dimensions, Booting Mode

## Changed in Rev.3

1. Change silkscreen at DDR2 component
2. Changed MS1V crystal footprint
3. Changed TS101 button footprint
4. Add Pull-up resistors to NAND RDY0/1
5. Add Pull-up resistors to I2C0
6. Add optional SPI TSC2046 connection
7. Add 22R resistor to SSP0\_CLK

Title			
Size: A4	Number:	Revision:	
Date: 11.02.2013	Time: 11:17:33	Sheet of	
www.evodbg.com			

U4A IMX287

EMI_A14	N10	DDR_A14
EMI_A13	T9	DDR_A13
EMI_A12	U11	DDR_A12
EMI_A11	T10	DDR_A11
EMI_A10	U13	DDR_A10
EMI_A09	P10	DDR_A9
EMI_A08	U9	DDR_A8
EMI_A07	N11	DDR_A7
EMI_A06	R9	DDR_A6
EMI_A05	R11	DDR_A5
EMI_A04	U10	DDR_A4
EMI_A03	T11	DDR_A3
EMI_A02	U14	DDR_A2
EMI_A01	U12	DDR_A1
EMI_A00	U15	DDR_A0
EMI_BA2	N12	DDR_BA2
EMI_BA1	T12	DDR_BA1
EMI_BA0	T16	DDR_BA0
EMI_D15	F17	DDR_DR15
EMI_D14	F13	DDR_DR14
EMI_D13	H17	DDR_DR13
EMI_D12	H13	DDR_DR12
EMI_D11	J14	DDR_DR11
EMI_D10	G14	DDR_DR10
EMI_D09	H15	DDR_DR9
EMI_D08	G16	DDR_DR8
EMI_D07	M17	DDR_DR7
EMI_D06	L14	DDR_DR6
EMI_D05	P17	DDR_DR5
EMI_D04	P13	DDR_DR4
EMI_D03	N14	DDR_DR3
EMI_D02	P15	DDR_DR2
EMI_D01	M13	DDR_DR1
EMI_D00	N16	DDR_DR0
EMI_CLK	L17	DDR_CLKR_P
EMI_CLK	L16	DDR_CLKR_N
EMI_CKE	T13	DDR_CKE
EMI_CE0	P12	DDR_CS
EMI_CEI	P9	
EMI_WE	T15	DDR_WE
EMI_RAS	R16	DDR_RAS
EMI_CAS	U16	DDR_CAS
EMI_DQS1	J17	DDR_R0QS1_P
EMI_DQS1	J16	DDR_R0QS1_N
EMI_DQS0	K17	DDR_R0QS0_P
EMI_DQS0	K16	DDR_R0QS0_N
EMI_DQM1	F15	DDR_R0QM1
EMI_DQM0	M15	DDR_R0QM0
EMI_DDR_OPEN	K14	DDR_D0GATE0
EMI_DDR_OPEN_FB	L15	DDR_D0GATE1
EMI_VREF1	K13	VREF_DDR2
EMI_VREF0	R14	
EMI_ODT1	T17	DDR_ODT
EMI_ODT0	R17	DDR_ODT

ClassName: DDR2  
i  
DDR2

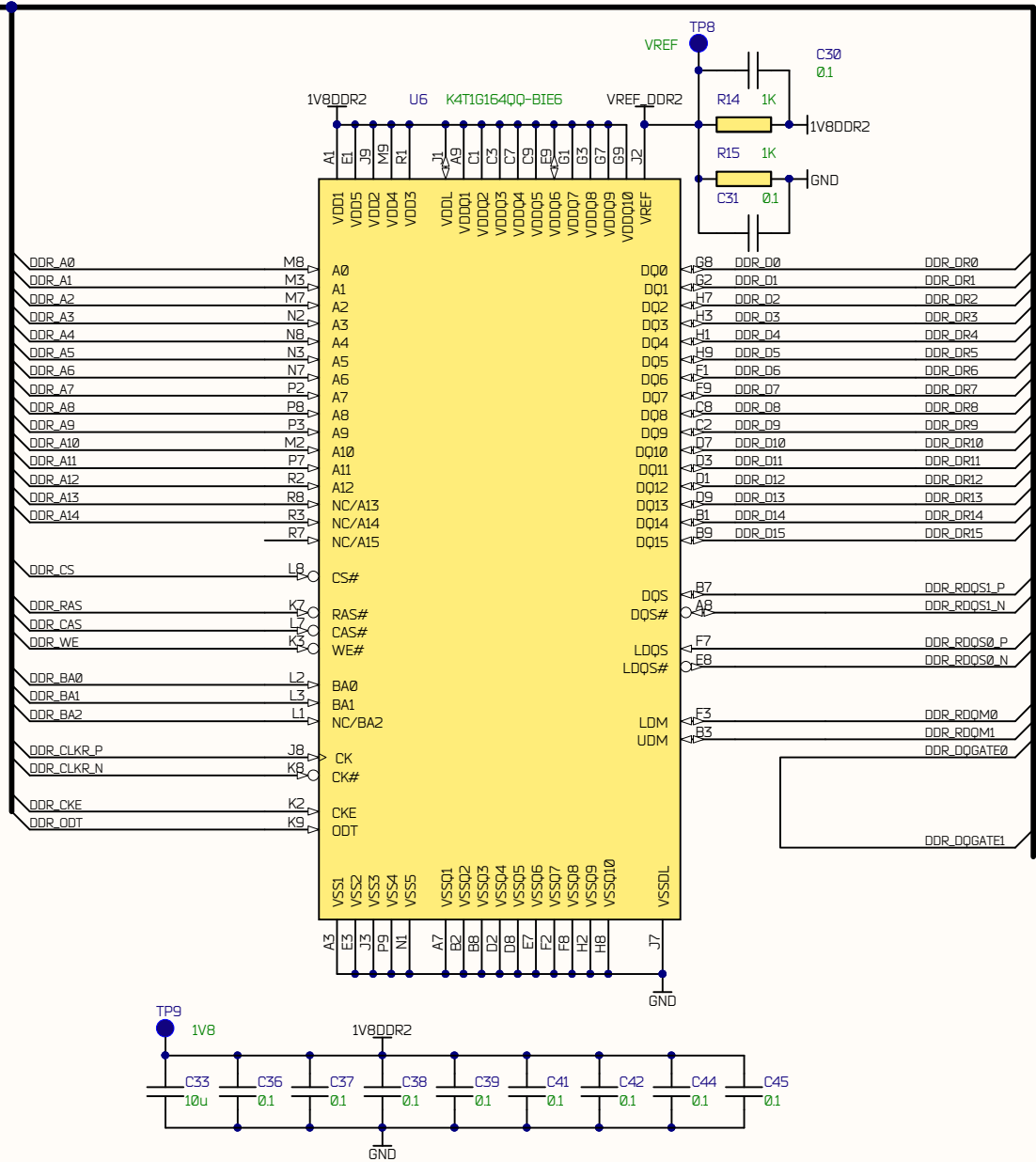

Title <b>EV-IMX287</b>		
Size: <b>A4</b>	Number:	Revision: <b>rev.3</b>
Date: <b>11.02.2013</b>	Time: <b>10:59:32</b>	Sheet of
<a href="http://www.evodbg.com">www.evodbg.com</a>		



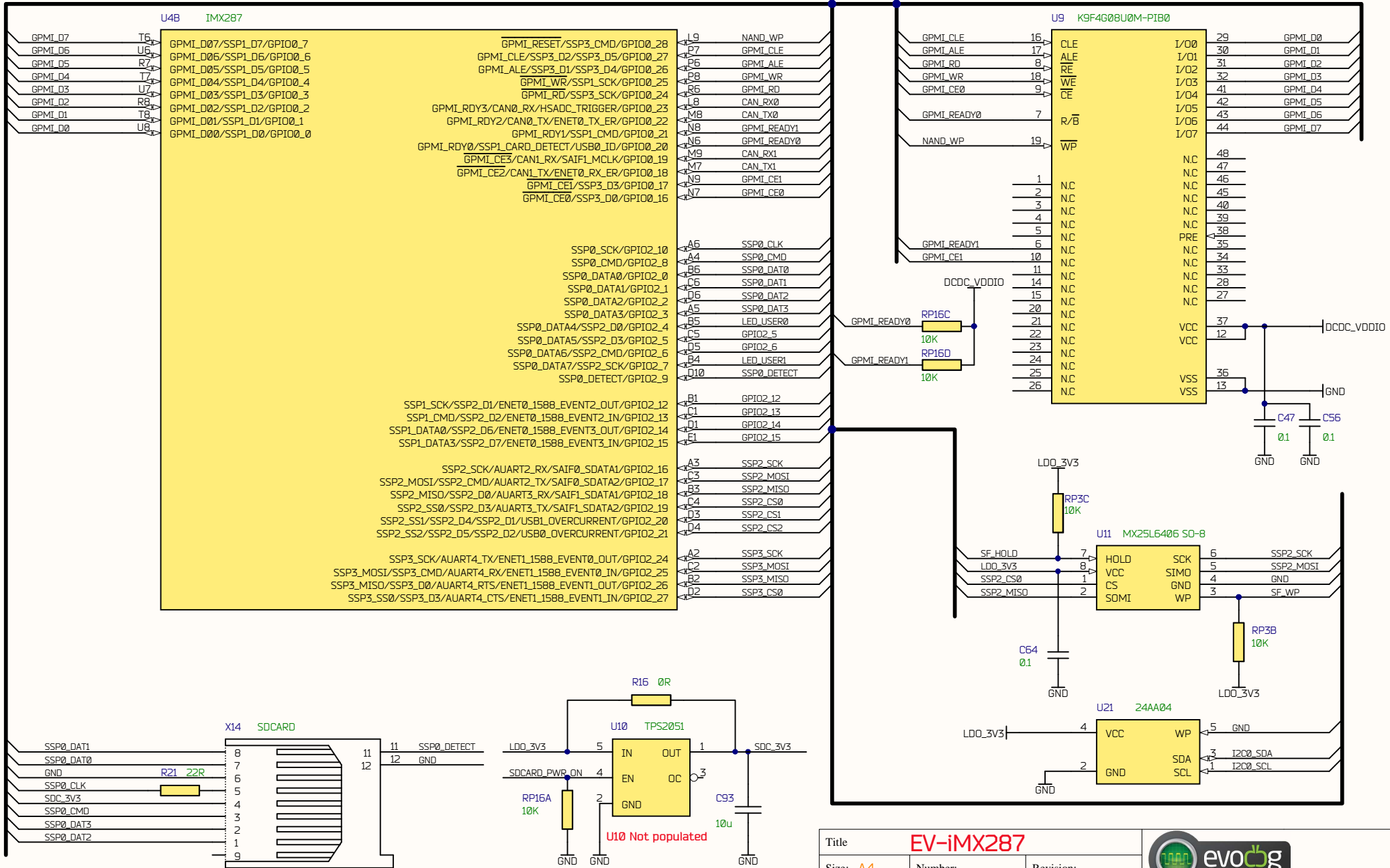

Title <b>EV-iMX287</b>		
Size: <b>A4</b>	Number:	Revision:
Date: <b>11.02.2013</b>	Time: <b>11:01:00</b>	Sheet of
<a href="http://www.evodbg.com">www.evodbg.com</a>		



D

C

B

U40 IMX287

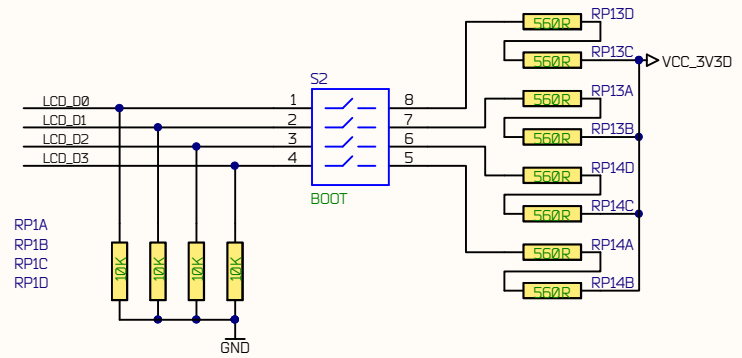
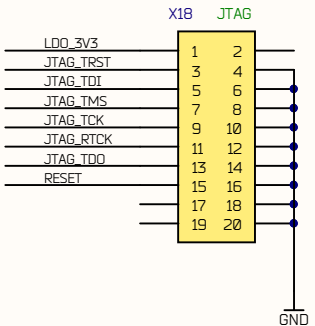
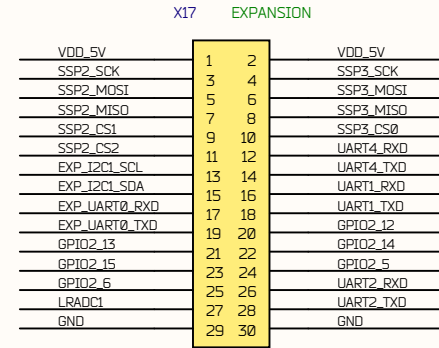
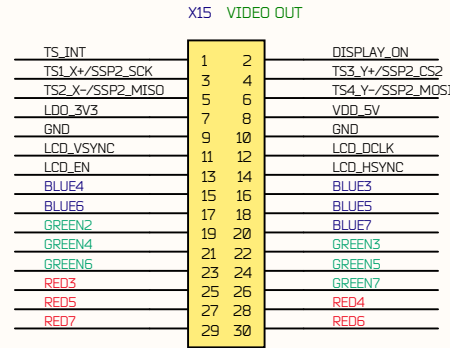
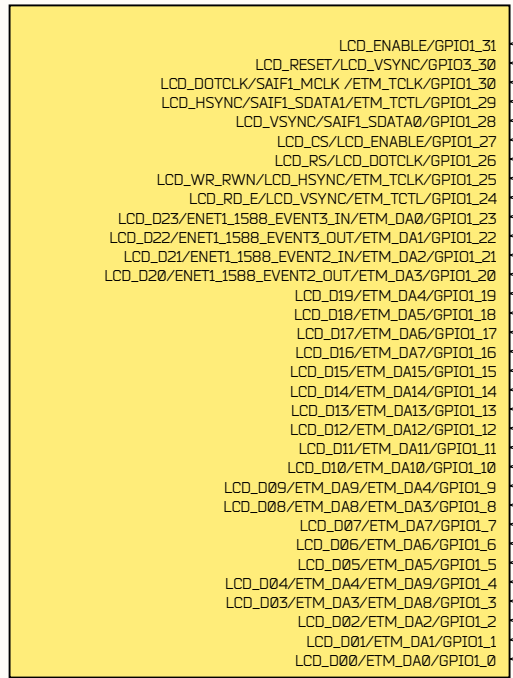

LRADC Touch Screen Based

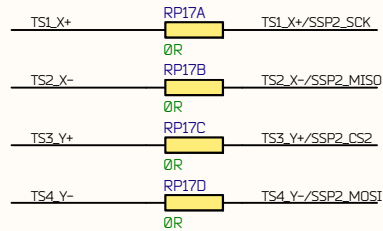

TSC2046 Touch Screen Based

DNP

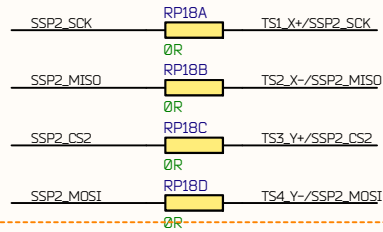

Voltage select 3V3

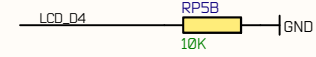

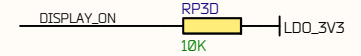
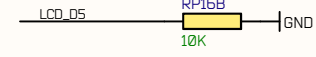

ETM Disable

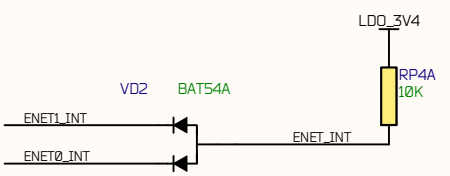

Title		<b>EV-iMX287</b>		
Size: A4	Number:	Revision: rev.3		
Date: 11.02.2013	Time: 11:05:30	Sheet	of	
www.evodbg.com				

U4C IMX287



Title		<b>EV-iMX287</b>		
Size: A4	Number:	Revision: rev.3		
Date: 11.02.2013	Time: 11:06:27	Sheet	of	
www.evodbg.com				

D

C

B

U4F IMX287

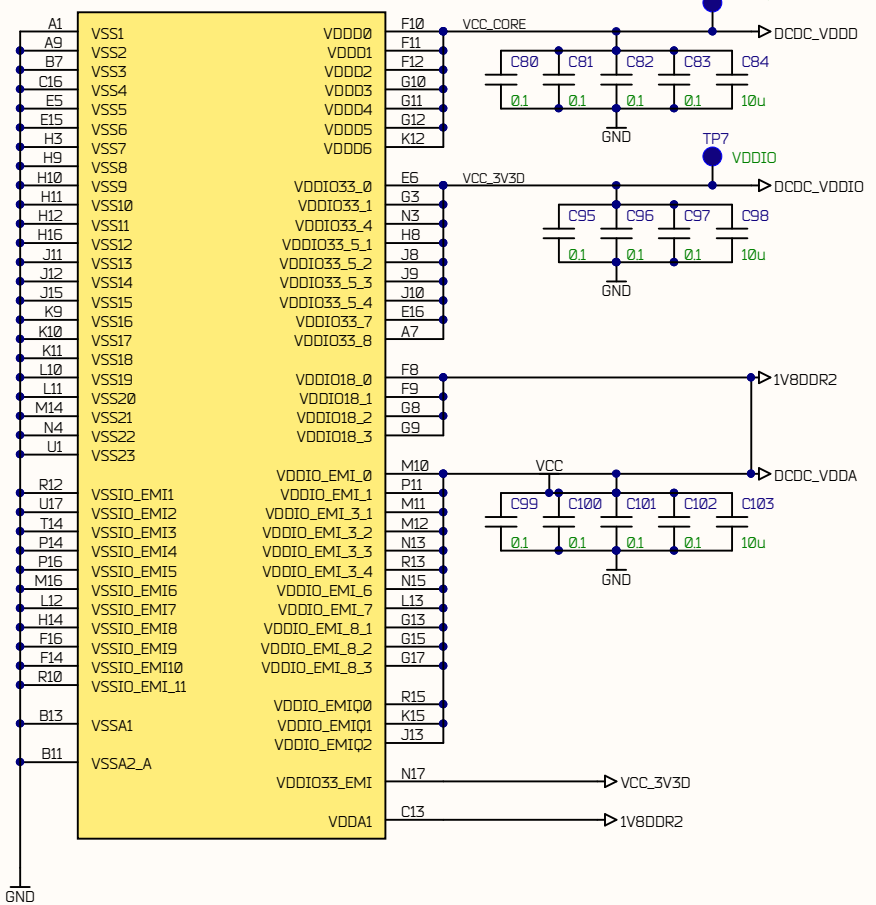

U4E IMX287

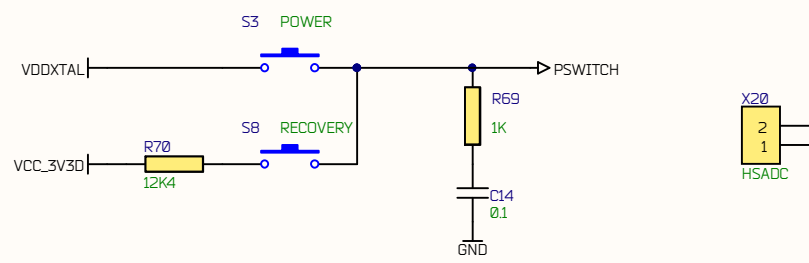
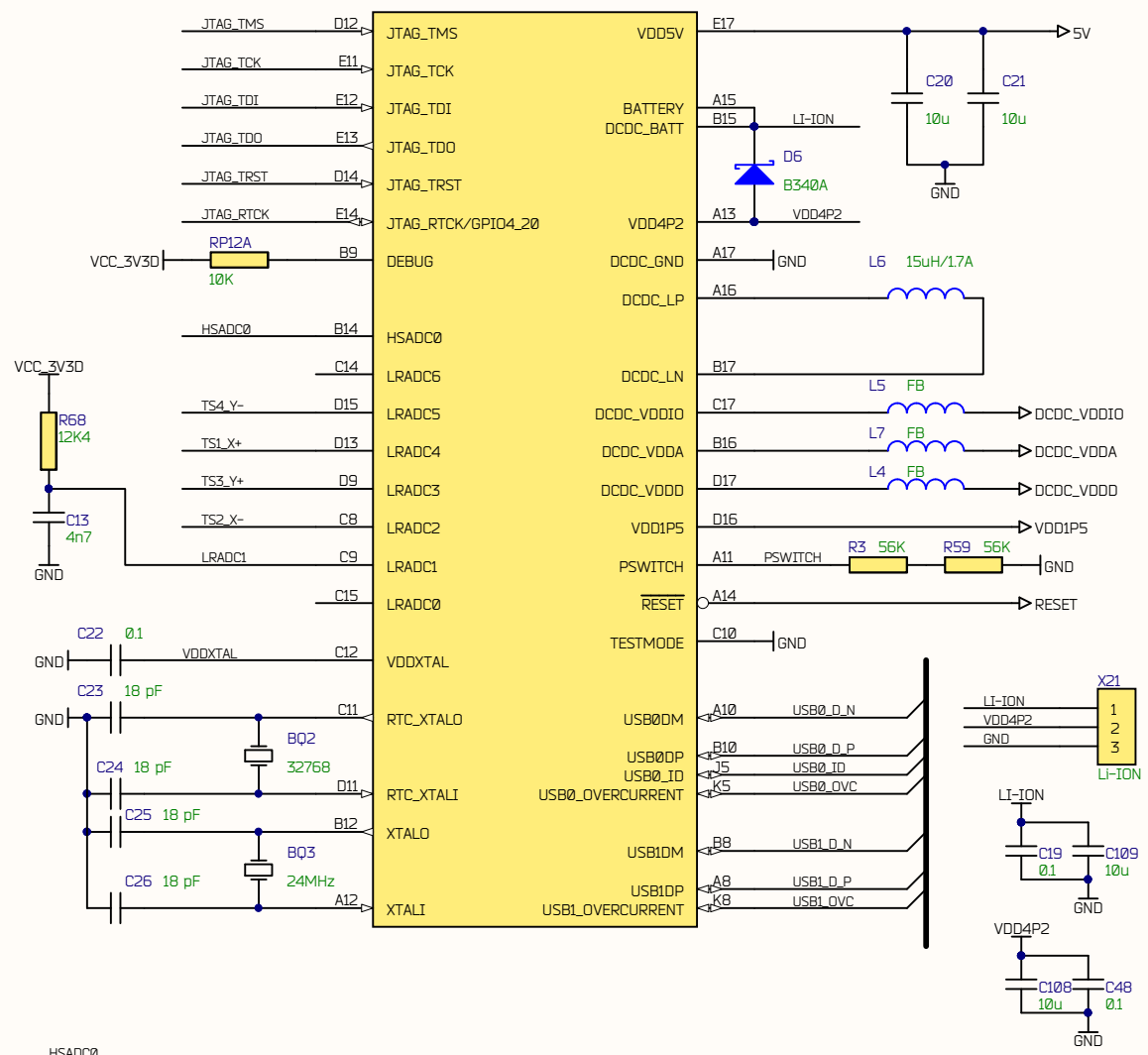

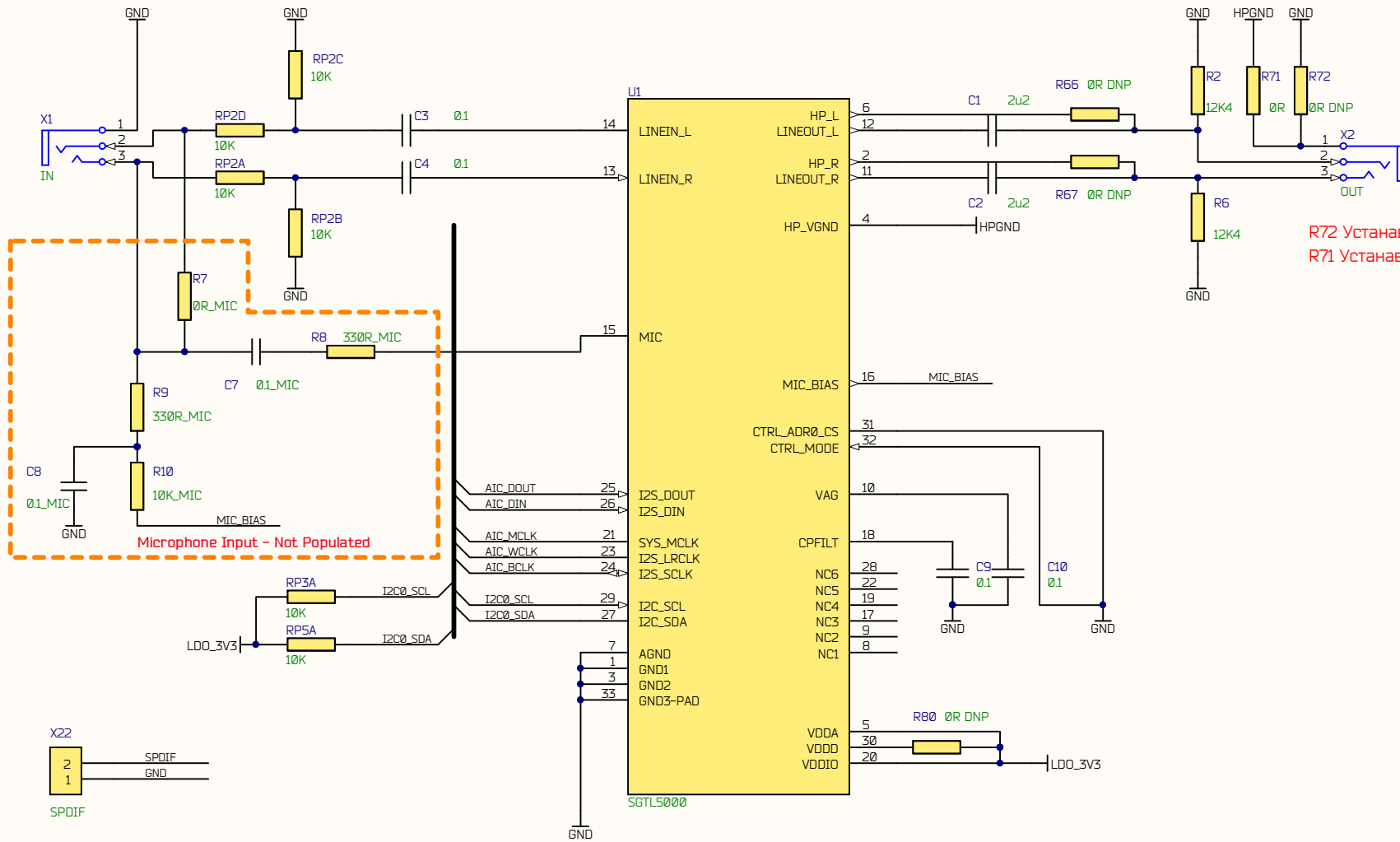

R72 Устанавливается при LINE OUT  
R71 Устанавливается при HP OUT

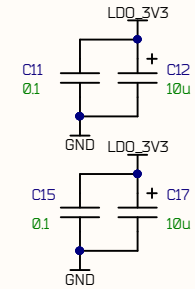

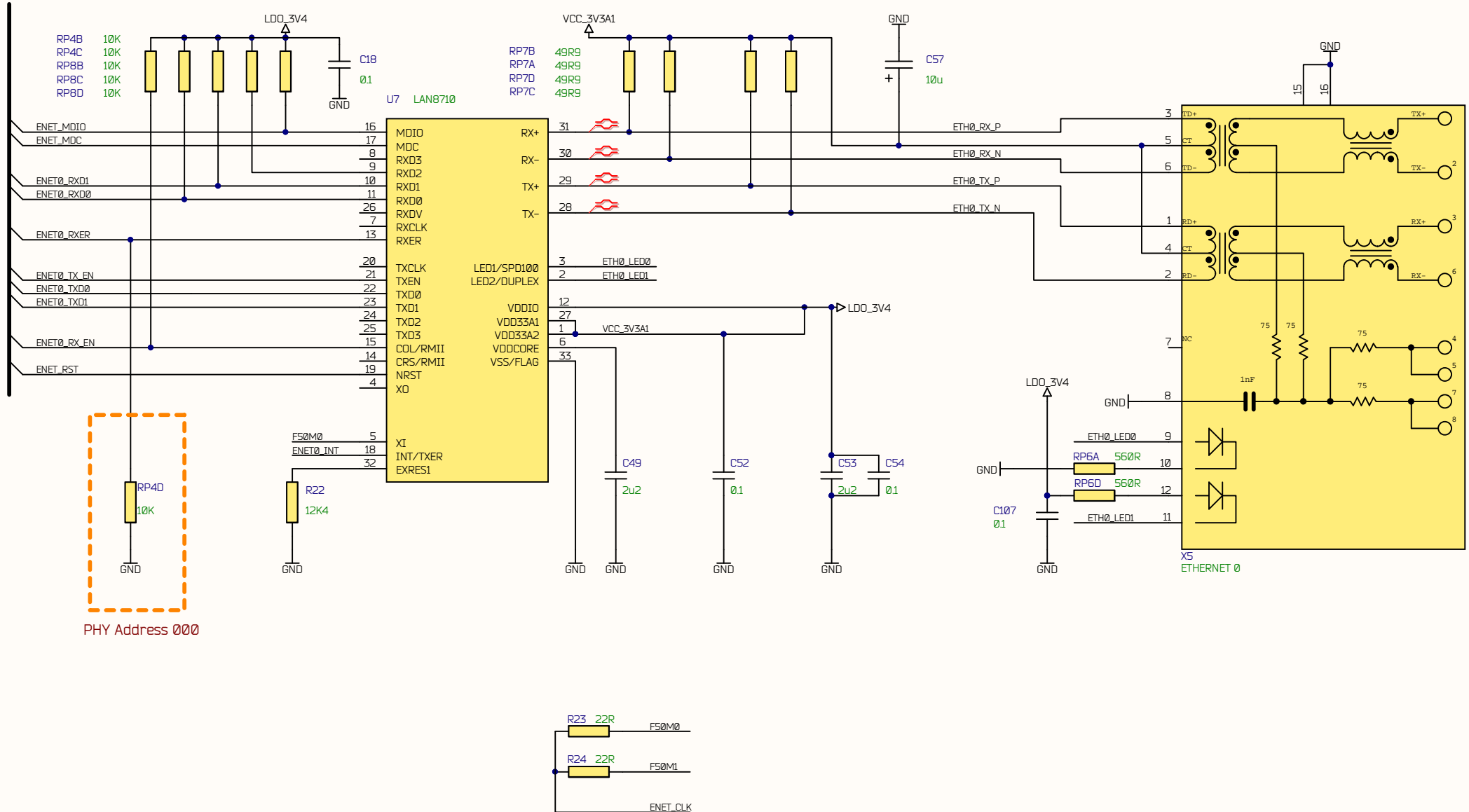



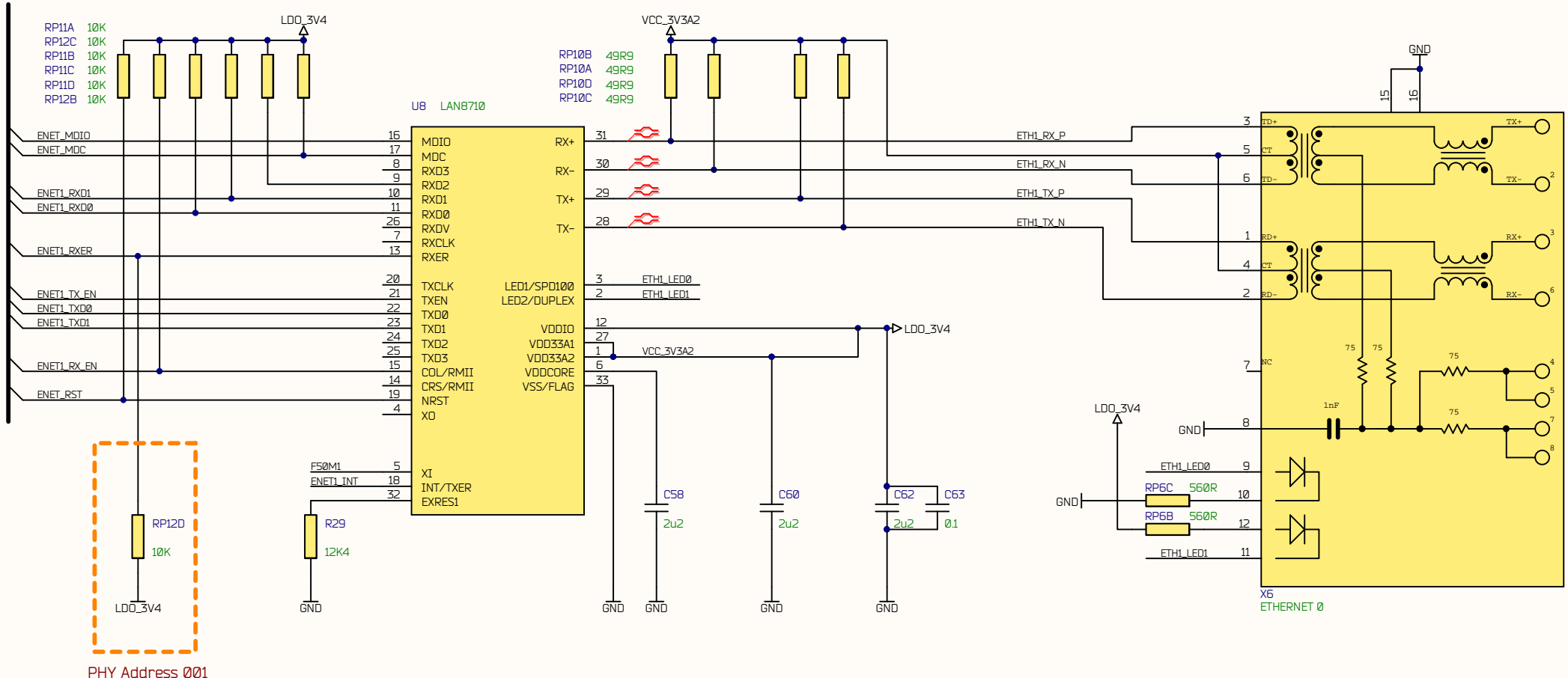

PHY Address 001

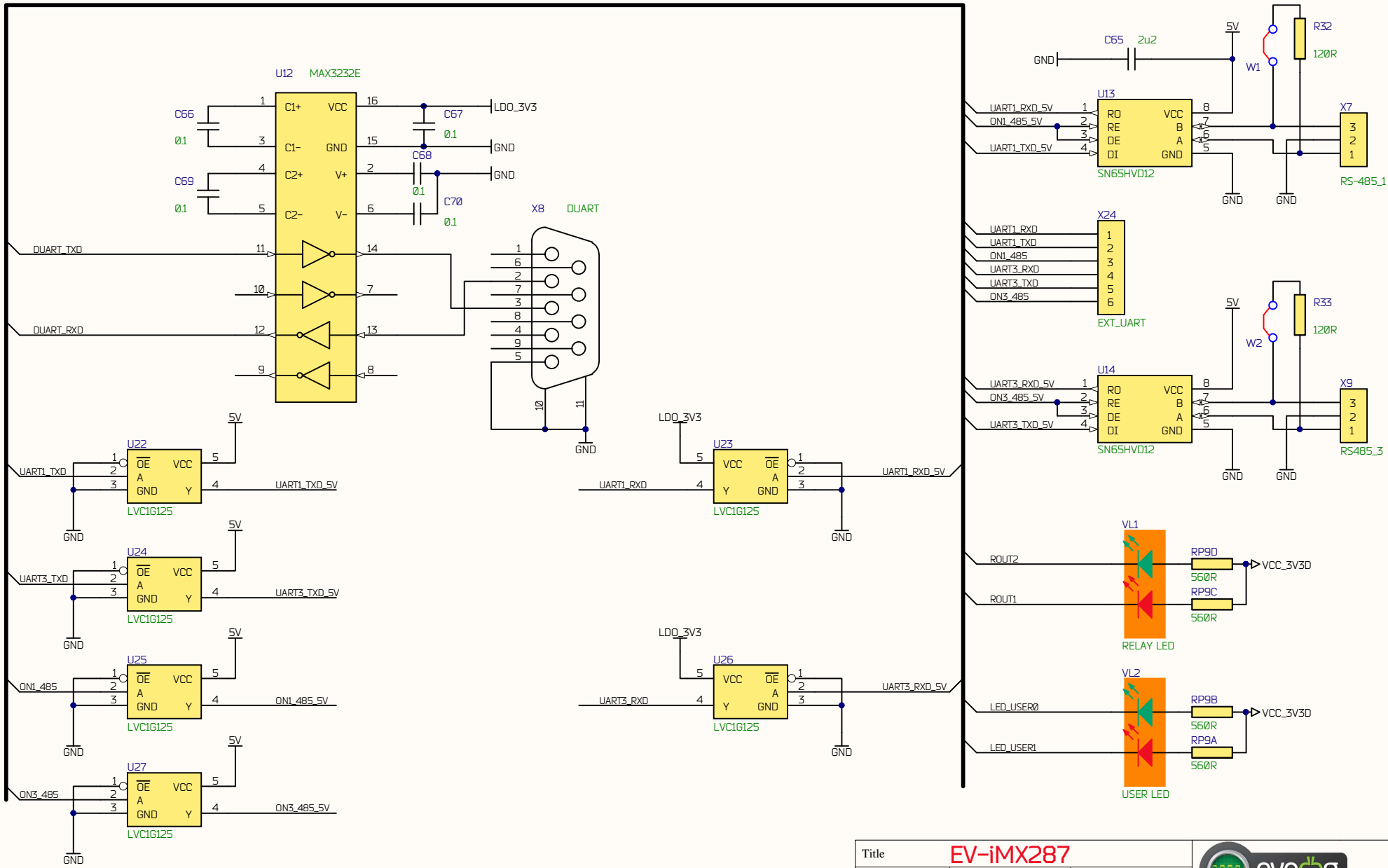

D

C

B

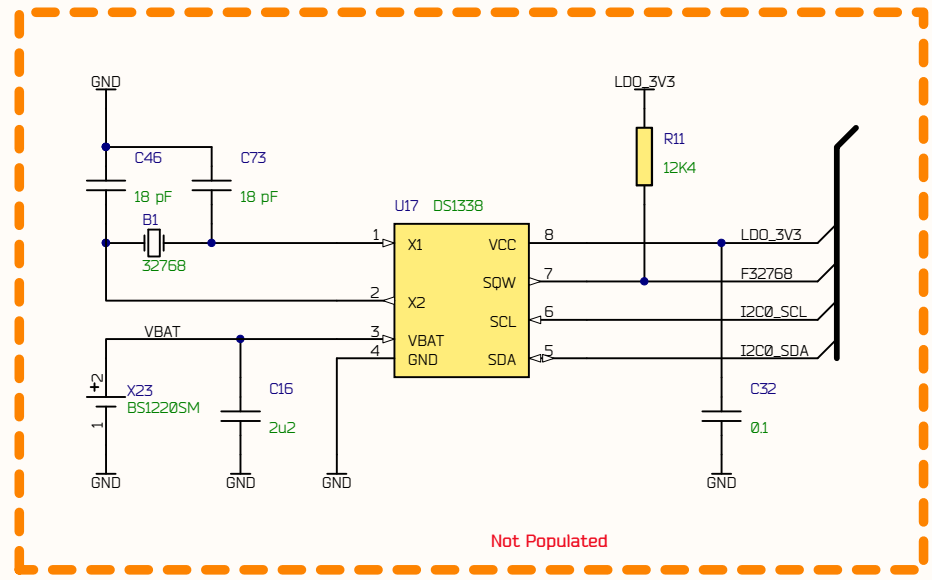
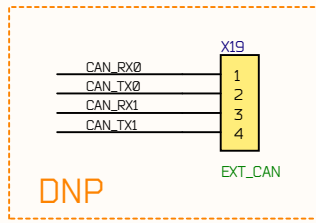
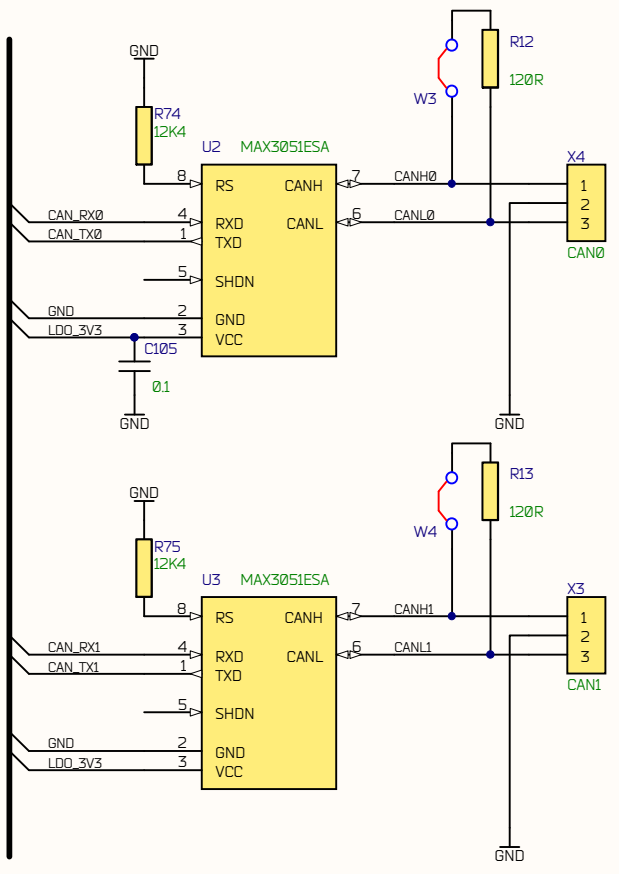

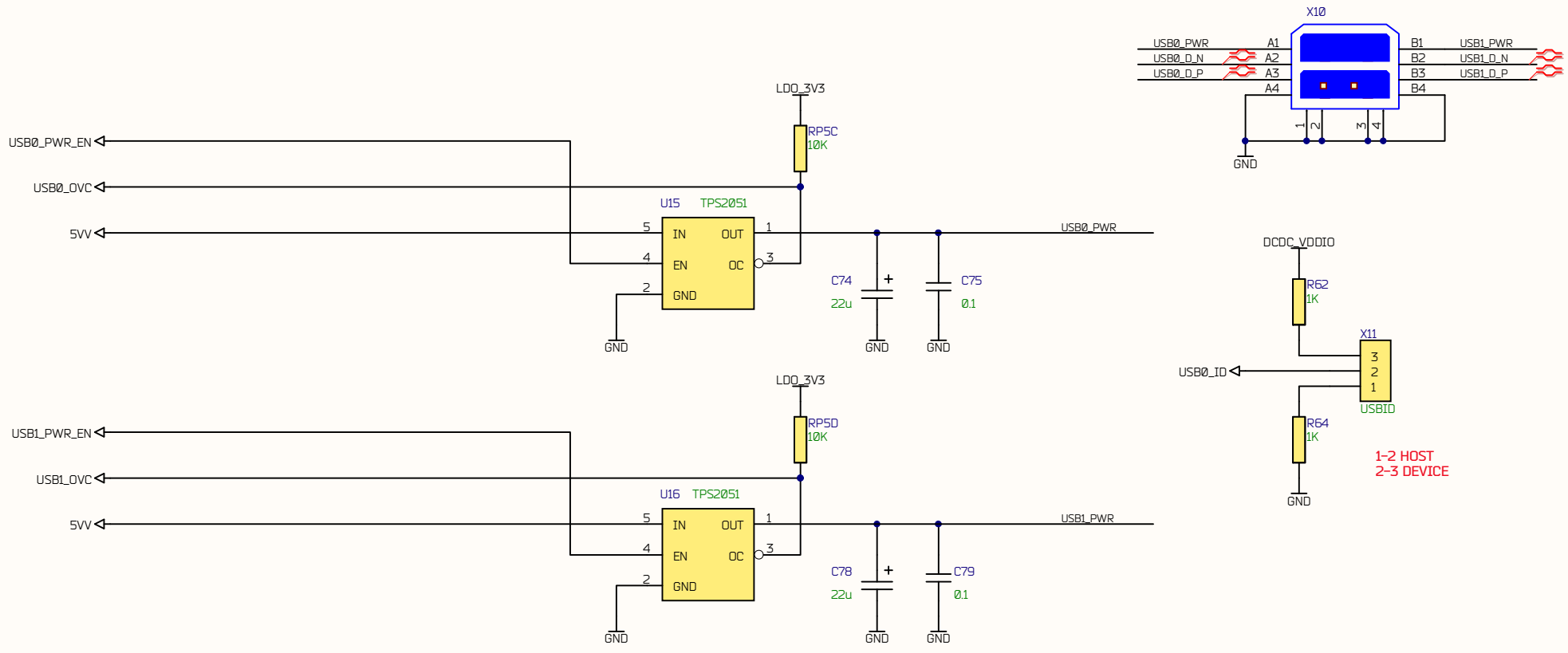

Title		<b>EV-iMX287</b>	
Size: A4	Number:	Revision:	<b>rev.3</b>
Date: 11.02.2013	Time: 11:15:19	Sheet	of
www.evodbg.com			



D

C

B

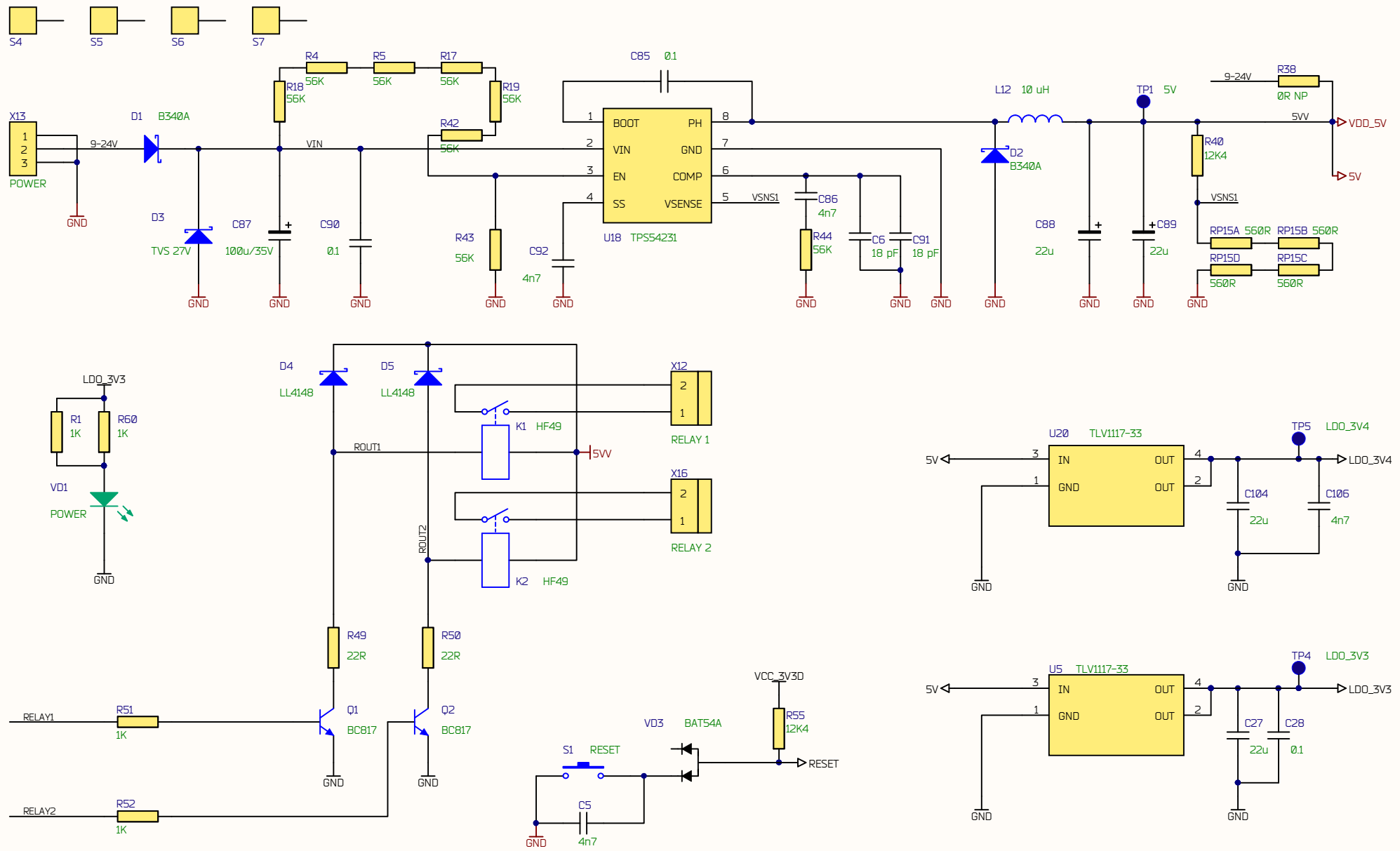

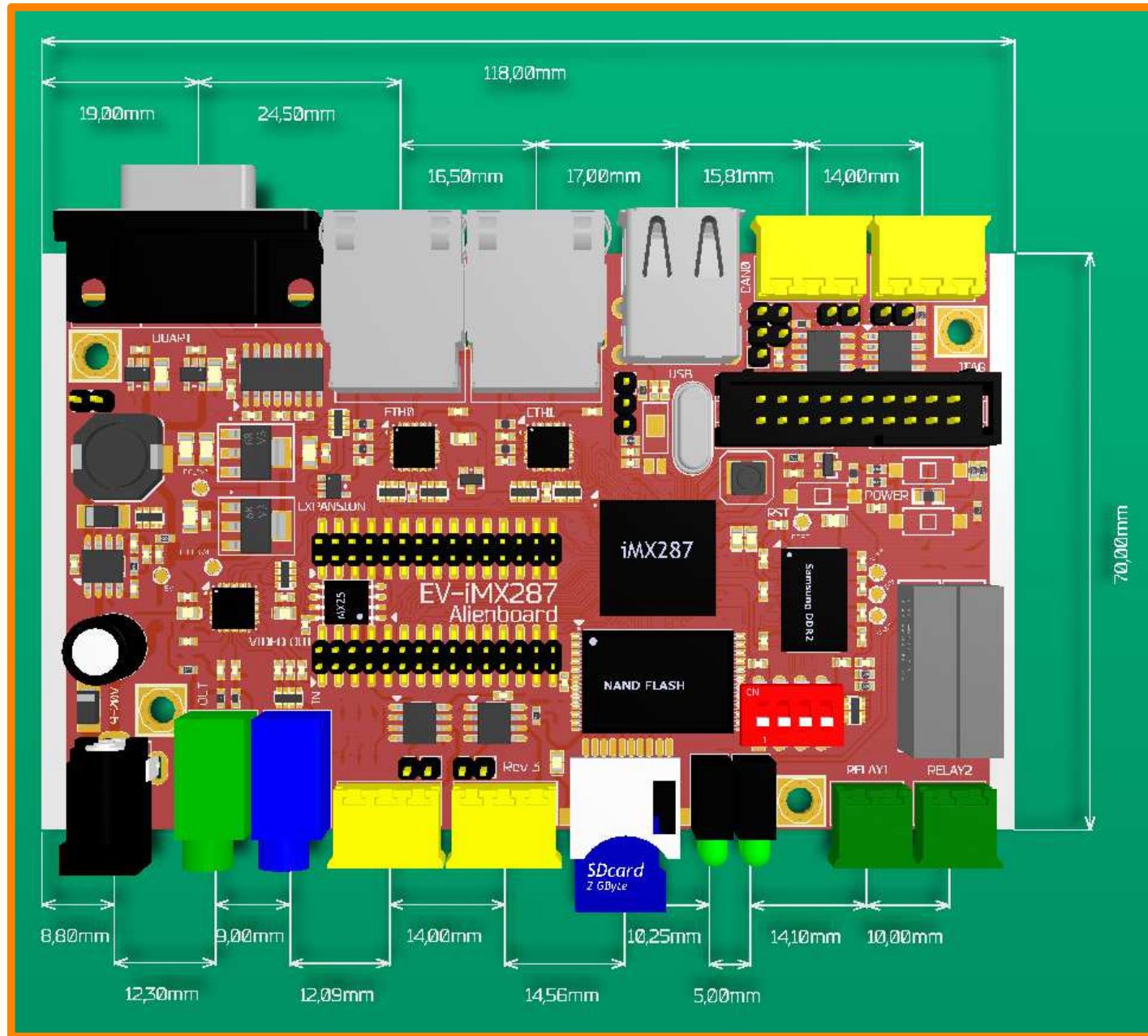

Dimensions

### Booting Mode

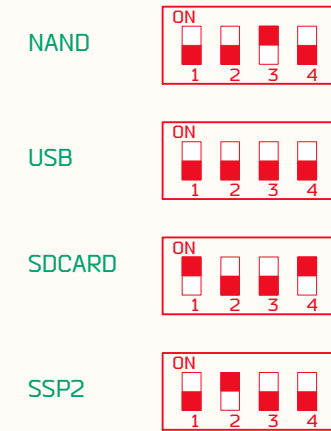

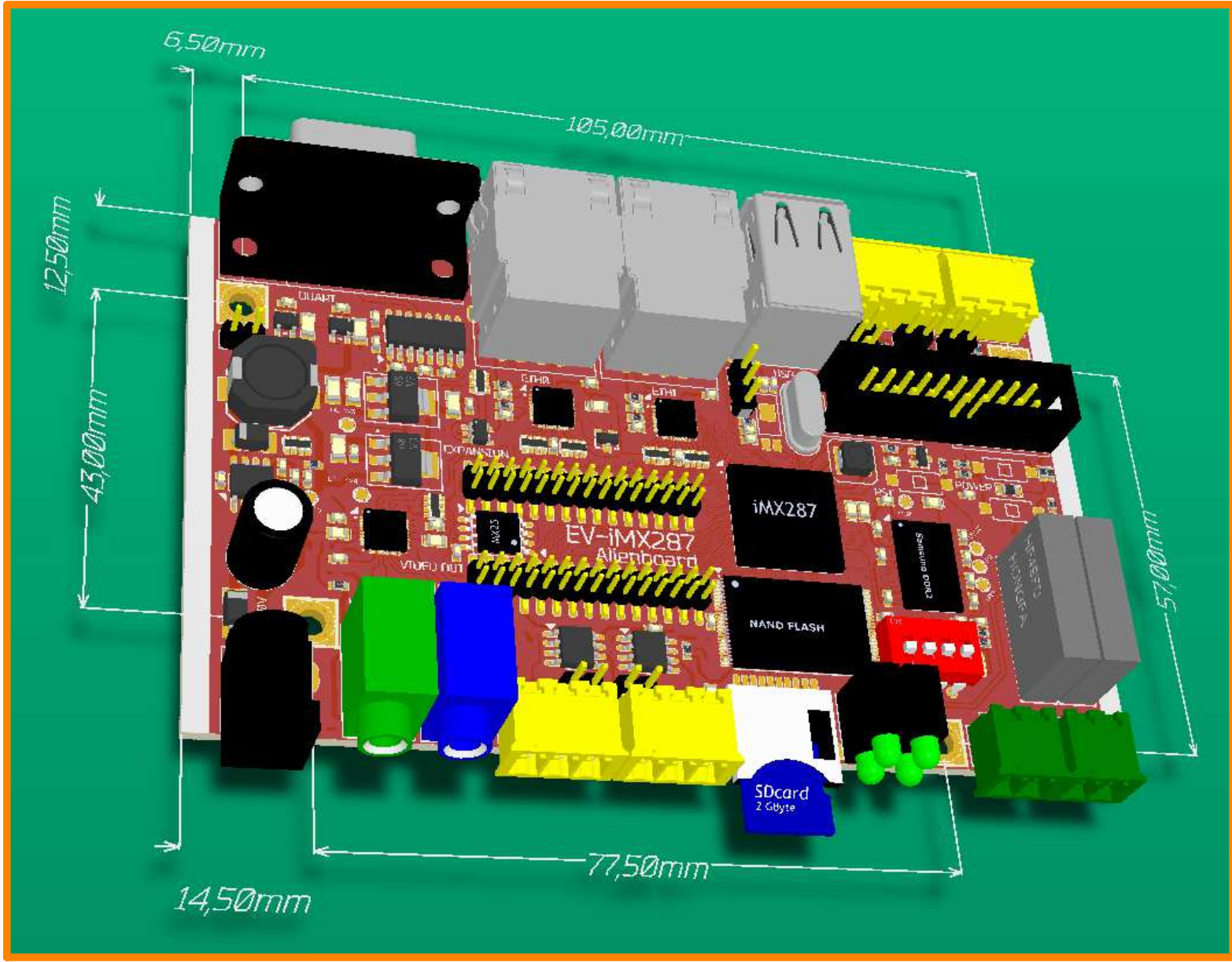

Mounting Holes