

USER MANUAL

2014

EV-iMX287-NANO Module

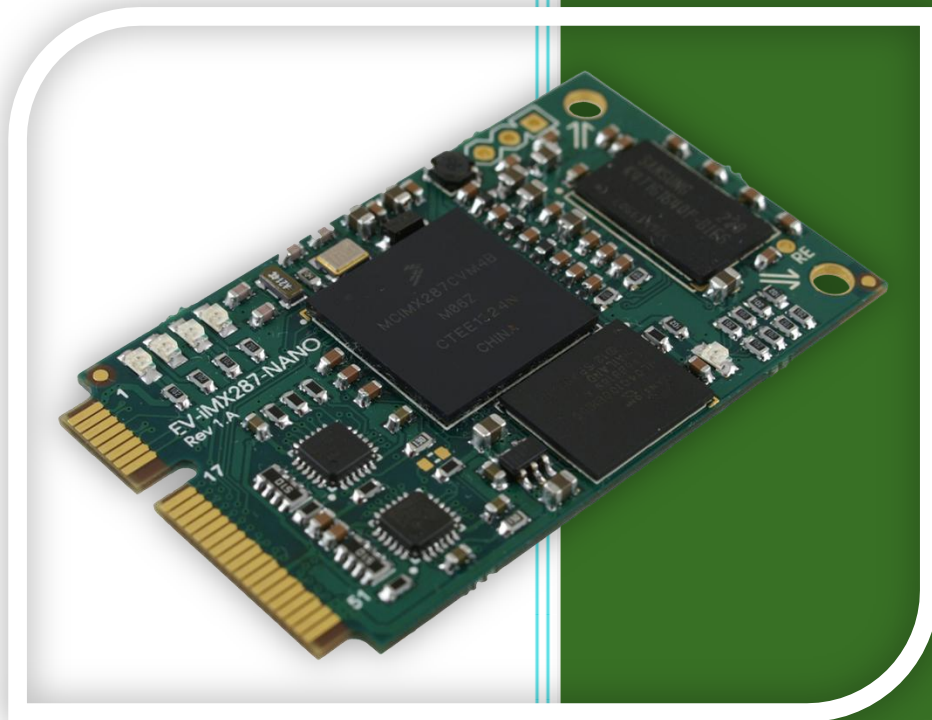

Revision 1.0

Evodbg

TABLE OF CONTENTS

Acronym and definitions 4

What’s included 5

Order information 5

A shot module description 5

iMX28 CPU’s compare..... 5

IMX287 Application Processor 6

EV-iMX287-NANO Module structure..... 7

A main components on module 8

Power system 8

Ethernet..... 8

Module main connector 9

52-pin main connector..... 10

Signals used in module 11

Boot modes 12

Memory..... 12

 NAND Flash Memory 12

 SPI Flash Memory 12

 DDR2 Memory..... 12

Dimension..... 13

Connector for ev-imx287-nano module..... 13

Tip’s 14

 EFuse..... 14

 I/O ports 14

 Power 14

 DUART interface 14

 SD/MMC..... 14

 Ethernet connection 14

 USB interface..... 15

 CAN Interface 15

EV-iMX287-NANO OEM module

I2C interface..... 15

SPI (SSP2) Interface 15

UART interface 16

Li-ION battery connector..... 16

Linux kernal and rootfs repair 16

Used materials 17

WEB 17

Contacts..... 17

This document history 17

ACRONYM AND DEFINITIONS

Acronym	Description
ADC	Analog to Digital Converter
ARM	Advanced Risc Machine
BSP	Board Support Package
CAN	Controller Area Network
CPU	Central Processing Unit
DDR	Double Data Rate
GPIO	General Purpose Input Output
I2C	Inter Integrated Circuit
JTAG	Joint Test Action Group
LCD	Liquid Crystal Display
Mb	Megabit
MB	Megabyte
MMC	Multimedia Card
NAND	
NC	Not Connected
OTG	On-The-Go
PHY	Physical
PWM	Pulse Width Modulation
RMII	Reduced Media Independent Interface
RTC	Real Time Clock
SD	Secure Digital
SLC	Single Layer Cell
SPI	Serial Peripheral Interface
SSI	Synchronous Serial Interface
UART	Universal Asynchronous Receiver Transmitter
USB	Universal Serial Bus
WP	Write Protect
WVGA	Wide Video Graphics Array

WHAT'S INCLUDED

Name	Quantity
EV-iMX287-NANO Module	1 pcs

ORDER INFORMATION

Name	Description
EV-iMX287-NANO-A1	iMX287, 128MB DDR2, 256MB SLC NAND Flash, Two Ethernet PHY -40C...+85C
EV-iMX287-NANO-A2	iMX287, 128MB DDR2, 256MB SLC NAND Flash, One Ethernet PHY -40C...+85C

Remark - for other module configuration please contact - info@otladka.com.ua

A SHOT MODULE DESCRIPTION

EV-iMX287-NANO - a small, Mini-PCI-Express format (not pin compatible with PCI-E standart!) MCIMX287/MCIMX283 ARM9 CPU based module. Max CPU frequency - 454 МГц.

- CPU - Freescale MCIMX287CVM4B or MCIMX283DVM4B
- DDR2 K4T1G164QQE 128MB Memory
- SLC NAND Flash S34ML02G100 256 MB Memory
- Optional SPI Flash MX25LC6406 64Mb Memory
- Two PHY Ethernet LAN8720AI chips
- 52-pin connector with Power and Interfaces signals
- Power Supply - 5V
- Power - 1Wt
- Module dimension 51*30*4 mm
- Weight - 10 gr.

IMX28 CPU'S COMPARE

Module	i.MX280	i.MX281	i.MX283	i.MX285	i.MX286	i.MX287
Application UART	5	5	5	5	5	5
Debug UART	1	1	1	1	1	1
Flex CAN	-	2	-	2	2	2
High-speed ADC	1	1	1	1	1	1
L2Switch	-	-	-	-	-	Yes
LCD интерфейс	No	No	Yes	Yes	Yes	Yes
LowSpeed ADC	8	8	8	8	8	8
PWM	8	8	8	8	8	8
SPDIF выход	No	Yes	No	Yes	Yes	Yes
SD/SDIO/MMC	4	4	4	4	4	4

EV-iMX287-NANO OEM module

Security	Yes	Yes	Yes	Yes	Yes	Yes
SPI	4	4	4	4	4	4
Touchscreen	No	No	Yes	Yes	Yes	Yes
USB 2.0 OTG	1	1	1	1	1	1
USB 2.0 HOST	1	1	1	1	1	1

IMX287 APPLICATION PROCESSOR

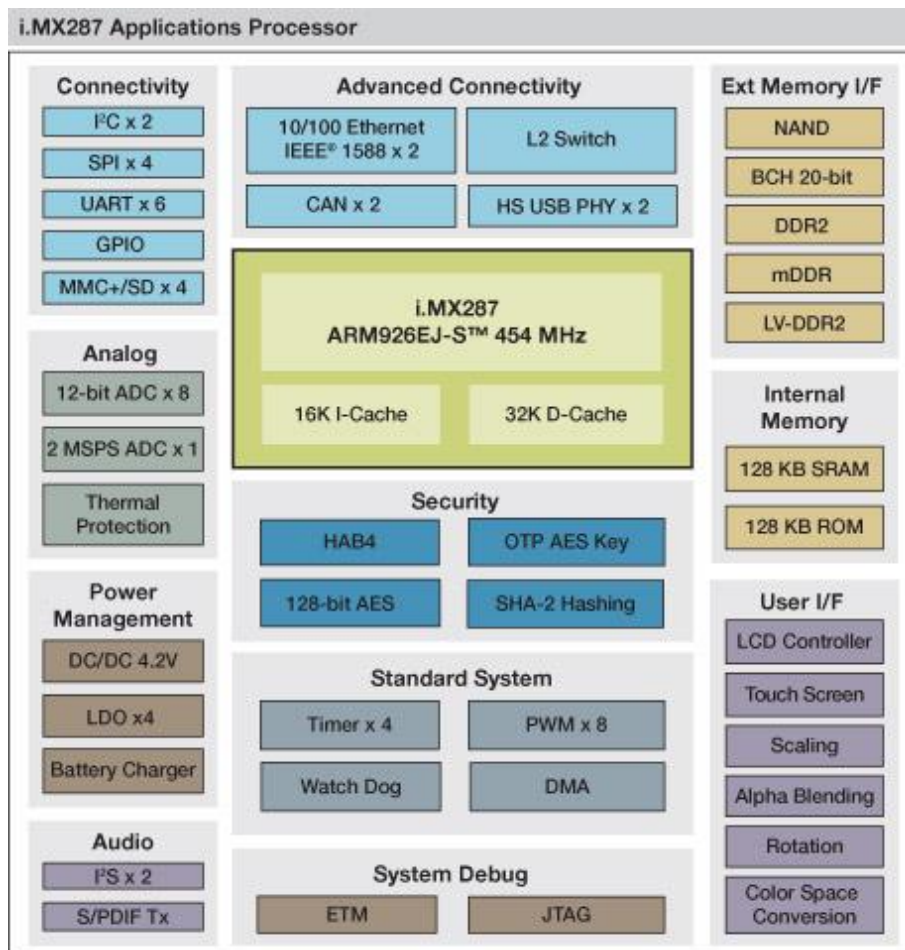

EV-IMX287-NANO MODULE STRUCTURE

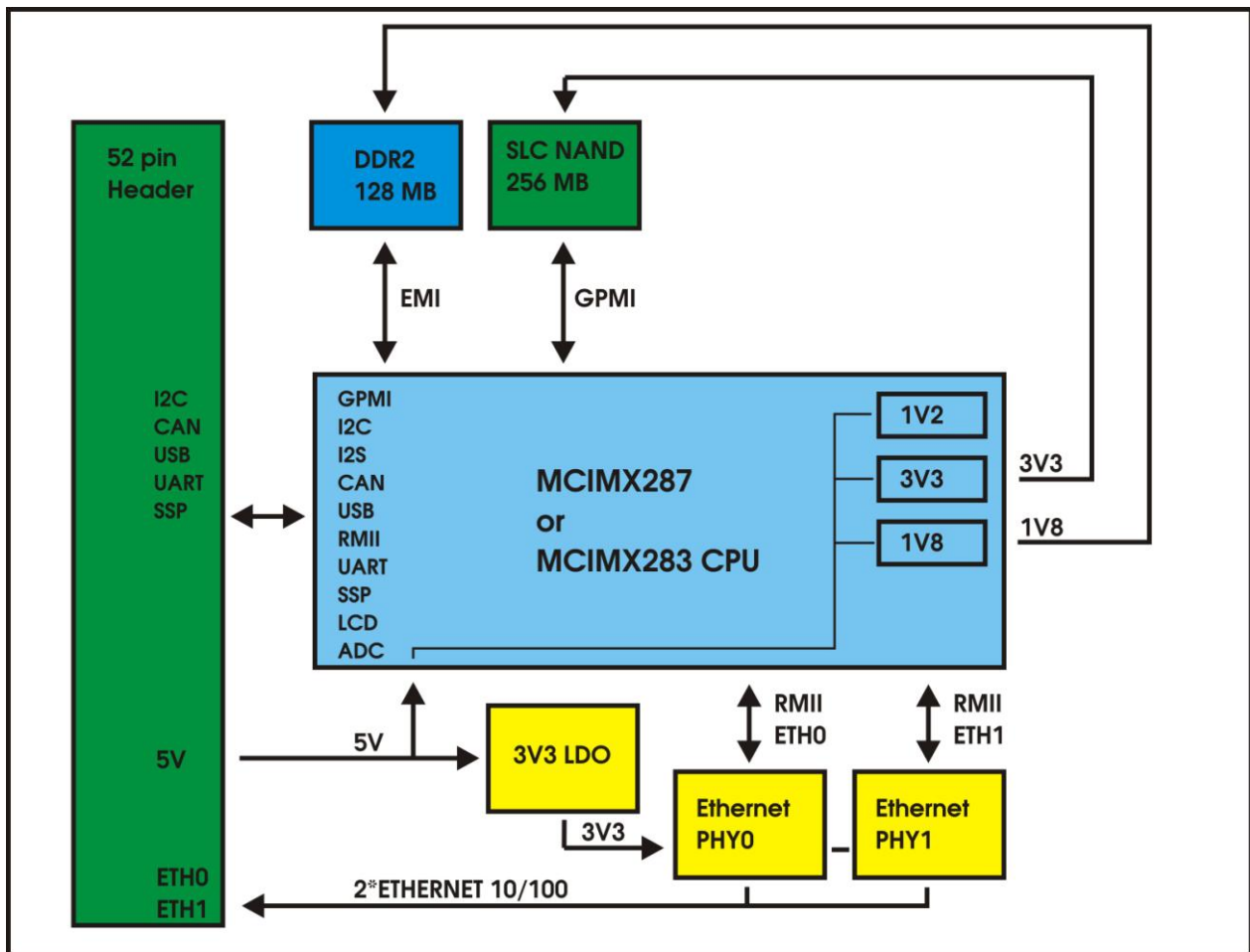

A MAIN COMPONENTS ON MODULE

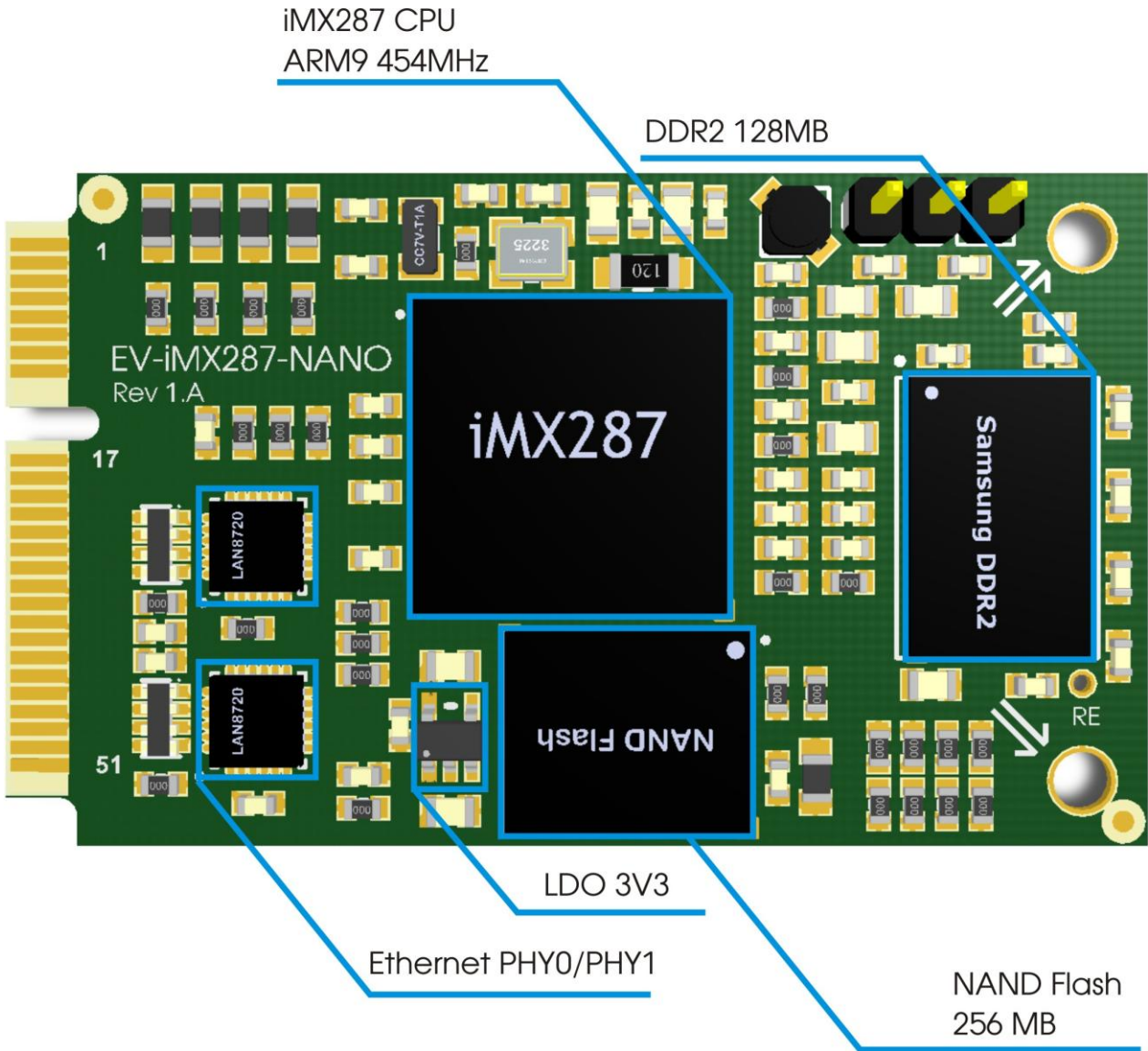

POWER SYSTEM

EV-iMX287-NANO works with a single power supply 5V (±5%). Power for DDR2 Memory (1.8V), processor core (1.2V) and I/O power (3.3V) generate iMX287 CPU. For Ethernet PHY's chip power used a 3.3V LDO TPS76333 (U1).

ETHERNET

On module present two LAN8720 (U5/U7) PHY Ethernet 10/100Mb chips which connected to iMX287 processor via RMI interface. TX/RX signals connected to 52-pin main connector. LED's signal a not connected to main connector. For current mode indication (Link/ACT) used four LED's on module.

MODULE MAIN CONNECTOR

EV-iMX287-NANO top view (3D model).

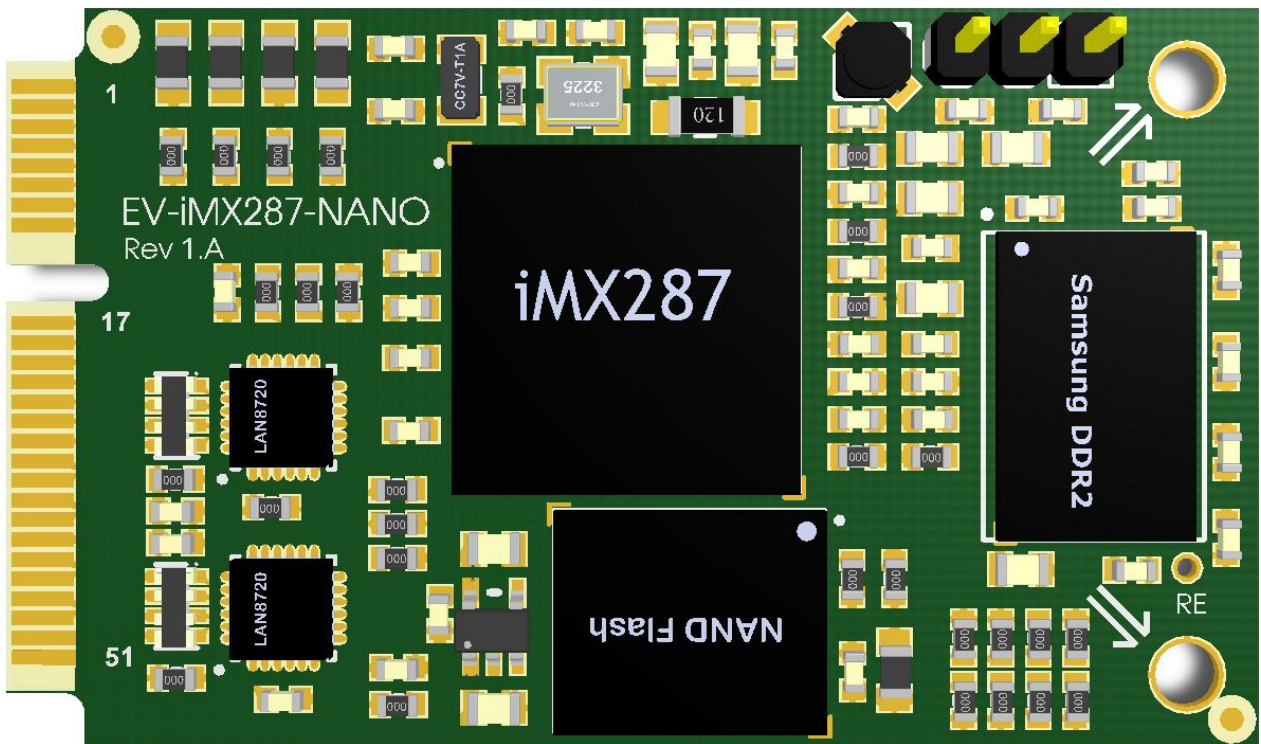

52-PIN MAIN CONNECTOR

Table 1: Main connector Pinout description

PIN number	PIN name	MUX1	MUX2	MUX3	GPIO	CPU pin
1	GND					
2	GND					
3	USB0DM					A10
4	SSPO_SCK	SSPO_SCK			GPIO2_10	A6
5	USB0DP					B10
6	SSPO_CMD	SSPO_CMD			GPIO2_8	A4
7	PWM2	PWM2	USB0_ID	USB1_OVERCURRENT	GPIO3_18	K8
8	SSPO_DATA0	SSPO_DATA0			GPIO2_0	B6
9	USB1DM					B8
10	SSPO_DATA1	SSPO_DATA1			GPIO2_1	C6
11	USB1DP					A8
12	SSPO_DATA2	SSPO_DATA2			GPIO2_2	D6
13	PWM0	PWM0	I2C1_SCL	DUART_RX	GPIO3_16	K7
14	SSPO_DATA3	SSPO_DATA3			GPIO2_3	A5
15	PWM1	PWM1	I2C1_SDA	DUART_TX	GPIO3_17	L7
16	SSPO_DETECT	SSPO_CARD_DETE CT				D10
17	AUART0_RX	AUART0_RX	I2C0_SCL	DUART_CTS	GPIO3_0	G5
18	SSP2_SCK	SSP2_SCK	AUART2_RX	SAIF0_SDATA1	GPIO2_16	A3
19	AUART0_TX	AUART0_TX	I2C0_SDA	DUART_RTS	GPIO3_1	H5
20	SSP2_MISO	SSP2_D0	AUART3_RX	SAIF1_SDATA1	GPIO2_18	B3
21	AUART1_RX	AUART1_RX	SSP2_CARD_DETE ECT	PWM_0	GPIO3_4	L4
22	SSP2_MOSI	SSP2_CMD	AUART2_TX	SAIF0_SDATA2	GPIO2_17	C3
23	AUART1_TX	AUART1_TX	SSP3_CARD_DETE ECT	PWM1	GPIO3_5	K4
24	SSP2_SS0	SSP2_D3	AUART3_TX	SAIF1_SDATA2	GPIO2_19	C4
25	AUART2_CTS	AUART2_CTS	I2C1_SCL	SAIF1_BITCLK	GPIO3_10	H6
26	SSP2_SS1	SSP2_D4	SSP2_D1	USB1_OVERCURRENT	GPIO2_20	D3
27	AUART2_RTS	AUART2_RTS	I2C1_SDA	SAIF1_LRCLK	GPIO3_11	H7
28	AUART2_RX	AUART2_RX	SSP3_D1	SSP3_D4	GPIO3_8	F6
29	RESETN					A14
30	AUART2_TX	AUART2_TX	SSP3_D2	SSP3_D5	GPIO3_9	F5
31	ETH0_TX_N	Сигнал LAN8720				
32	AUART3_RX	AUART3_RX	CAN0_TX	EN- ET0_1588_EVENT0_O UT	GPIO3_12	M5
33	ETH0_TX_P	Сигнал LAN8720				
34	AUART3_TX	AUART3_TX	CAN0_RX	EN- ET0_1588_EVENT0_IN	GPIO3_13	L5
35	ETH0_RX_N	Сигнал LAN8720				
36	AUART0_CTS	AUART0_CTS	AUART4_RX	DUART_RX	GPIO3_2	J6
37	ETH0_RX_P	Сигнал LAN8720				
38	AUART0_RTS	AUART0_RTS	AUART4_TX	DUART_TX	GPIO3_3	J7
39	VOUT 3V3					
40	I2C0_SCL	I2C0_SCL	TIMROT_ROTAR YA	DUART_RX	GPIO3_24	C7
41	ETH1_TX_N	Сигнал LAN8720				
42	I2C0_SDA	I2C0_SDA	TIMROT_ROTAR YB	DUART_TX	GPIO3_25	D8
43	ETH1_TX_P	Сигнал LAN8720				
44	GPMI_RDY3	GPMI_RDY3	CAN0_RX	HSADC_TRIGGER	GPIO0_23	L8

EV-iMX287-NANO OEM module

45	ETH1_RX_N	Сигнал LAN8720				
46	GPMI_RDY2	GPMI_RDY2	CAN0_TX	ENET0_TX_ER	GPIO0_22	M8
47	ETH1_RX_P	Сигнал LAN8720				
48	GPMI_CE3N	GPMI_CE3N	CAN1_RX	SAIF1_MCLK	GPIO0_19	M9
49	5V					
50	GPMI_CE2N	GPMI_CE2N	CAN1_TX	ENET0_RX_ER	GPIO0_18	M7
51	5V					
52	5V					

SIGNALS USED IN MODULE

Table 2: Inside used pins

CPU pin number	Name	Used for	Connect to main connector
G4	ENET0_MDC	LAN8720	No
H4	ENET0_MDIO	LAN8720	No
E4	ENET0_RX_EN	LAN8720	No
H1	ENET0_RXD0	LAN8720	No
H2	ENET0_RXD1	LAN8720	No
F4	ENET0_TX_EN	LAN8720	No
F1	ENET0_TXD0	LAN8720	No
F2	ENET0_TXD1	LAN8720	No
E3	ENET0_TX_CLK	LAN8720	No
F3	ENET0_RX_CLK	LAN8720	No
J1	ENET0_RXD2	LAN8720	No
J2	ENET0_RXD3	LAN8720	No
G1	ENET0_TXD2	LAN8720	No
G2	ENET0_TXD3	LAN8720	No
J4	ENET0_COL	LAN8720	No
J3	ENET0_CRS	LAN8720	No
E2	ENET_CLK	LAN8720	No
U8	GPMI_D0	NAND Flash	No
T8	GPMI_D1	NAND Flash	No
R8	GPMI_D2	NAND Flash	No
U7	GPMI_D3	NAND Flash	No
T7	GPMI_D4	NAND Flash	No
R7	GPMI_D5	NAND Flash	No
U6	GPMI_D6	NAND Flash	No
T6	GPMI_D7	NAND Flash	No
L9	GPMI_RESET	NAND Flash	No
P7	GPMI_CLE	NAND Flash	No
P6	GPMI_ALE	NAND Flash	No
P8	GPMI_WR	NAND Flash	No
R6	GPMI_RD	NAND Flash	No
N7	GPMI_CEO	NAND Flash	No
N6	GPMI_RDY0	NAND Flash	No
A3	SSP2_SCK	SPI Flash (optional)	Pin 18
C3	SSP2_MOSI	SPI Flash (optional)	Pin 22
B3	SSP2_MISO	SPI Flash (optional)	Pin 20
C4	SSP2_SS0	SPI Flash (optional)	Pin 24

BOOT MODES

If NAND Flash is programmed, after RESET module start booting from NAND Flash. If NAND Flash corrupted or not programmed the module start boot from USB0.

If you want to boot from SPI Flash you need to blow CPU e-Fuse via Freescale BitBurner software.

MEMORY

NAND FLASH MEMORY

S34ML02G100 Spansion SLC NAND Flash (U3) placed on module. Bus width 8 bit, 256 Mbyte. The NAND Flash connected to CPU via GPMI, used GPMI_CE0 for select chip and GPMI_RDY0 for Busy. GPMI_RESET signal used for Write Protect. For special request 512 MB NAND Flash can be placed on module.

SPI FLASH MEMORY

An option SPI Flash памяти MX25LC6406 (U6 64 Mbit can be placed on module. The SPI Flash Memory connected to SSP2 interfaces, CS0.

DDR2 MEMORY

DDR2 (U2) K4T1G164Q (or similar) 128 MByte. Maximum EMI interface clock 205 MHz.

EV-iMX287-NANO OEM module

DIMENSION

All dimension in mm. Maximum height of module is 4.0 mm.

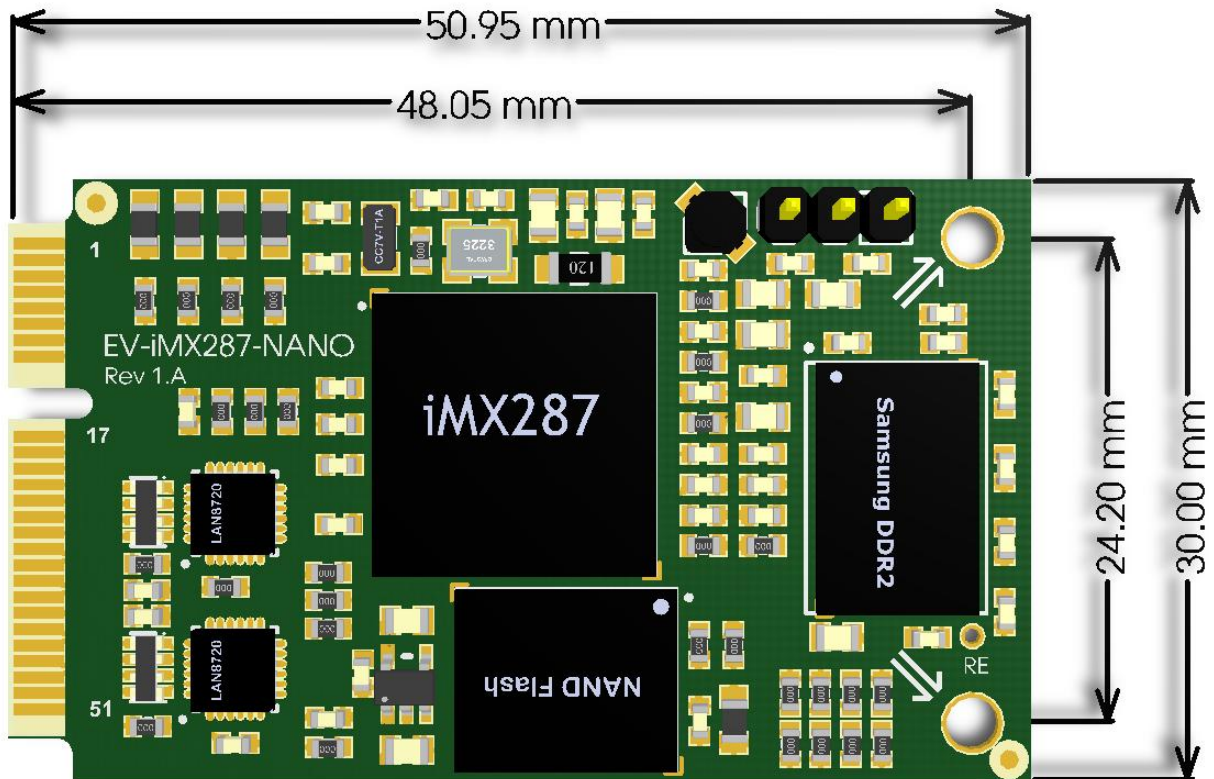

CONNECTOR FOR EV-IMX287-NANO MODULE

You can use any of standart mini PCI-e connector:

Molex - [0679100002](#)

TE Connectivity - [292443](#)

JAE Electronics - [MM60-52B1-G1-R850](#)



View of mini PCI Express connector .

TIP'S

EFUSE

The e-Fuse is not programmed. You can burn it via BitBurner software.

I/O PORTS

All signals (exlude Ethernet diff pair) has a 3.3V levels. Use level translators to connect for 1.8V/5.0V interfaces.

POWER

A 5V/1A power supply recommend to use with this module

DUART INTERFACE

DUART use for debug (console) in Linux application. You can use MAX3232 or similar converter for connect to PC. Also, any USB to Serial converter can be used (FT232, PL2303 etc.).

SD/MMC

To connect SD or mini SD card used SSP0 interface.

Table 3: SD/uSD card connect

Main connector pin	SD card pin number	microSD pin number	Pin description
4	5	5	SSP0_CLK
6	2	3	SSP0_CMD
8	7	7	SSP0_DAT0
10	8	8	SSP0_DAT1
12	9	1	SSP0_DAT2
14	1	2	SSP0_DAT3
16			SSP0_DETECT
1,2	3,6	6	GND
39	4	4	3.3V Power

Attention! You must pull-up SSP0_DETECT signal to 3.3V with external resistor 10K.

SSP0 can be work in 1/4/ bit modes.

ETHERNET CONNECTION

Example connection HR911105A RJ45 connector with build-in magnetics .

Таблица 4:

Module PIN number	HR911105A PIN number	Signal Name
33	1	TX+
31	2	TX-
37	3	RX+

EV-iMX287-NANO OEM module

35	6	RX-
1	8	GND
39	4,5	3.3B

Eth1 can be connect similar.

USB INTERFACE

EV-iMX287-NANO provides two USB High Speed interfaces. USB0 works in HOST/Device mode, USB1 only in HOST Mode.

Таблица 5:

Module PIN Number	Signal	Description
5	USB0_D+	
3	USB0_D-	
7	USB0_ID	HOST/Device Mode Select
11	USB1_D+	
9	USB1_D-	

CAN INTERFACE

Module provides two CAN interfaces. Any 3.3V CAN transceiver can be used (MAX3051, 65HVD232 etc.)

Table 6:

Module PIN number	Signal
46	CAN0_TX
44	CAN0_RX
50	CAN1_TX
48	CAN1_RX

I2C INTERFACE

Module provides two I2C interfaces. Place a pull-up resistor (2.2K-10K) on carrier board.

Table 7:

Module PIN number	Signal
40	I2C0_SCL
42	I2C0_SDA
25	I2C1_SCL
27	I2C1_SDA

SPI (SSP2) INTERFACE

Module provide one SPI interface (SSP2) with two Chip Select signals. If SPI Flash installed only SSP2_SS1 signal available.

EV-iMX287-NANO OEM module

Table 8:

Module PIN number	Signal
18	SSP2_SCK
20	SSP2_MISO
22	SSP2_MOSI
24	SSP2_SS0
26	SSP2_SS1

UART INTERFACE

Module provides five UART's.

Table 9:

Module PIN number	Signal
17	UART0_RXD
19	UART0_TXD
21	UART1_RXD
23	UART1_TXD
28	UART2_RXD
30	UART2_TXD
32	UART3_RXD
34	UART3_TXD
36	UART4_RXD
38	UART4_TXD

LI-ION BATTERY CONNECTOR

3-pin Li-ION battery connector.

Table 11:

Additional connector PIN number	Signal
1	LI-ION
2	VCC4P2
3	GND

LINUX KERNEL AND ROOTFS REPAIR

Freescale MFG Tools software used to repair NAND Flash image. Connect carrier board with EV-iMX287-NANO module installed to PC via USB0 connector. Apply power and run MFG Tools software. Select EV-iMX287-NANO_NAND_repair in drop-list. Press START button.

USED MATERIALS

Link	Description
iMX287CEC	i.MX28 Datasheet
iMX28CE	i.MX28 Errata
MCiMX28RM	Processor Reference Manual
K4T1G164 DDR2	DDR2 Datasheet
S34ML04G100 NAND Flash	NAND Flash Datasheet
LAN8720A Ethernet PHY	Ethernet PHY
24AA01 EEPROM	I2C EEPROM
MX25L6406E	SPI Flash
Carrier board project (Altium Designer)	
Carrier board schematic (pdf)	

WEB

Ukraine - <http://otladka.com.ua>

Russia - <http://www.starterkit.ru>

CONTACTS

03151, Ukraine, Kyiv, 7B Molodogvardeyskaya str, 4

Phone: 380-44-362-25-02

Mobile Phone: 380-91-910-68-18

Email: info@starterkit.ru, info@otladka.com.ua

For customize EV-iMX287-NANO module please email to pcb@evodbg.com



THIS DOCUMENT HISTORY

19/08/2014 - Initial revision 1.0